

CITY COUNCIL AGENDA

15728 Main Street, Mill Creek, WA 98012 (425) 745-1891



Pam Pruitt, Mayor • Brian Holtzclaw, Mayor Pro Tem • Sean Kelly
Donna Michelson • Vince Cavaleri • Mike Todd • Mark Bond

Regular meetings of the Mill Creek City Council shall be held on the first, second and fourth Tuesdays of each month commencing at 6:00 p.m. in the Mill Creek Council Chambers located at 15728 Main Street, Mill Creek, Washington. Your participation and interest in these meetings are encouraged and very much appreciated. We are trying to make our public meetings accessible to all members of the public. If you require special accommodations, please call the office of the City Clerk at (425) 921-5776 three days prior to the meeting.

The City Council may consider and act on any matter called to its attention at such meetings, whether or not specified on the agenda for said meeting. Participation by members of the audience will be allowed as set forth on the meeting agenda or as determined by the Mayor or the City Council.

To comment on subjects listed on or not on the agenda, ask to be recognized during the Audience Communication portion of the agenda. Please stand at the podium and state your name and address for the official record. Please limit your comments to the specific item under discussion. Time limitations shall be at the discretion of the Mayor or City Council.

Study sessions of the Mill Creek City Council may be held as part of any regular or special meeting. Study sessions are informal, and are typically used by the City Council to receive reports and presentations, review and evaluate complex matters, and/or engage in preliminary analysis of City issues or City Council business.

Next Ordinance No. 2017-824

Next Resolution No. 2017-571

**November 28, 2017
City Council Meeting
6:00 PM**

CALL TO ORDER

PLEDGE OF ALLEGIANCE

ROLL CALL

AUDIENCE COMMUNICATION

- A. Public comment on items on or not on the agenda

PRESENTATIONS

- B. Art & Beautification Board Appointment
(*City Council Interview Committee*)

STUDY SESSION

- C. 2018 Legislative Priorities
(*Rebecca C. Polizzotto, City Manager*)

NEW BUSINESS

- D. Mill Creek Sports Park - Freedom Field Rehabilitation Project Summary
(Rebecca C. Polizzotto, City Manager)

CONSENT AGENDA

- E. Approval of Checks #57778 through #57853 and ACH Wire Transfers in the Amount of \$1,046,875.06
(Audit Committee: Mayor Pruitt and Mayor Pro Tem Holtzclaw)
- F. City Council Meeting Minutes of November 7, 2017
- G. City Council Meeting Minutes of November 14, 2017

REPORTS

- H. Mayor/Council
- I. City Manager
- Situational Overview: Flooding Incident
 - Briefing on Proposed CPP
 - Council Planning Schedule

AUDIENCE COMMUNICATION

- J. Public comment on items on or not on the agenda

RECESS TO EXECUTIVE SESSION

(Confidential Session of the Council)

- K. Discussion of the performance of a public employee per RCW 42.30.110 (1)(g)

ADJOURNMENT



Agenda Item # B
Meeting Date: November 28, 2017

CITY COUNCIL AGENDA SUMMARY
City of Mill Creek, Washington

AGENDA ITEM: APPOINTMENT TO THE ART & BEAUTIFICATION BOARD

PROPOSED MOTION:

Motion to appoint a new member to serve a one-year term on the Art & Beautification Board.

KEY FACTS AND INFORMATION SUMMARY:

There is one position on the Art & Beautification Board that expires on October 31, 2018. Notices soliciting a new member were posted at City Hall (North and South), on the City's website and a press release was sent to the local newspapers.

One individual submitted a letter of interest for the vacant position on the Art & Beautification Board. The interview is scheduled with the Council Interview Committee at 5:30 p.m. on Tuesday, November 28, before the Council meeting.

CITY MANAGER RECOMMENDATION:

N/A

ATTACHMENTS:

Written response expressing a desire to serve on the Art and Beautification Board from:

- Benjamin Briles

Respectfully Submitted:

A handwritten signature in blue ink that reads "Rebecca C. Polizzotto".

Rebecca C. Polizzotto
City Manager

To Whom It May Concern,

My name is Benjamin Briles, residing at 1431 141st Ct SE in Mill Creek, WA 98012. I am interested in joining the Mill Creek Arts & Beautification Board. I am primarily motivated by an interest in serving my community in whatever way my skills can be best used.

I have a background in engineering, having graduated with a B.S. in Aerospace Engineering and working for Boeing for 12 years, from supporting the International Space Station, to improving the design of the 787 and 777X.

My wife and I bought our house in Mill Creek because we love being surrounded by the tall trees, seemingly enveloped in natural beauty, while still having the convenience of most necessary services as close as the Mill Creek Town Center. We felt it would be a good community to raise our two small children. I want to ensure that those things remain true as the city grows in population, and one way I believe I can do that is to join the Arts & Beautification Board, where I can discuss proposed plans and ideas to maintain and improve the beauty of our community, while maintaining a budget. I think there are many ways we can maintain and improve the looks of our city, while keeping costs low.

I love the Pianos on Main Street project, having obtained the pianos and their decoration from the community for low cost, being both an assistance to those who have unwanted pianos, and to provide them for free access in the fantastic Town Center. I greatly appreciate the Great Garden Award program, where community members are recognized for maintaining a wonderful garden, visible to the community, and only at the cost of an annual plaque program.

I would like to discuss implementing a painted rock project, where community members can paint rocks, and then hide them for other folks to find along our pathways, brightening their day. Finally, I would like to discuss beginning a community garden project, possibly in or near the Town Center, both for visibility, and proximity and ease of access to many of our community members. I believe that working with the soil in a place greatly increases one's attachment to that place, and I believe it might help to strengthen our citizens' bonds to the city.

Thank you,

Benjamin Briles



Agenda Item # C
Meeting Date: November 28, 2017

CITY COUNCIL AGENDA SUMMARY
City of Mill Creek, Washington

AGENDA ITEM: 2018 LEGISLATIVE PRIORITIES WORK SESSION

PROPOSED MOTION:
N/A

KEY FACTS AND INFORMATION SUMMARY:

The 2018 legislative session is quickly approaching. In preparation for the session, the City should identify priorities for its legislators. The City’s legislative delegation & AWC representatives have been invited to attend the Council’s work session tonight.

Lingering Issue: Capital Budget

The 2017 legislative session was the longest in history and yielded numerous helpful policy and budget actions for Washington’s 281 cities and towns. However, critical issues remain unresolved. One such issue is the adoption of a capital budget, which directly impacts Mill Creek.

The turf field replacement at the Mill Creek Sports Park is on the state’s Recreation and Conservation Office Youth Athletic Facilities Grant list for \$250,000; lack of a capital budget means that we’ve not been able to receive this grant funding. The Legislature needs to swiftly adopt a capital budget so that critical community projects can move forward.

New Priorities

The Association of Washington Cities (AWC) has identified four key priorities for the 2018 legislative session.

1. Strengthen city tools to address housing conditions in our communities

Cities large and small are experiencing challenges with housing in their community – from shortages of affordable housing, to a lack of workforce housing, to neighborhood impacts of abandoned foreclosed properties. Cities need a variety of local option tools to address the problems of their specific local circumstances. AWC urges the Legislature to adopt:

- A new construction sales tax reimbursement pilot program to attract new multi-family housing in cities outside of the urban core;
- A means for cities to mitigate the impacts of abandoned and bank-owned foreclosed homes; and
- Additional flexibility with existing tools such as making the optional sales tax authority for affordable housing a council decision.

2. Direct funds to mental health, chemical dependency, and social safety net programs

Although Mill Creek is not a frontline service provider, many of the problems associated with mental health and chemical dependency show up in our community and on our

streets. Increasingly, local public safety personnel play an expanding role in addressing these impacts and connecting those in need of such programs with resources at the county or state level. Many of the people that Mill Creek Police encounter through law enforcement-related activity are in need of chemical dependency and/or mental health help. There is an increasing need to have such resources in this region and in Snohomish County. Without appropriate funding, those people within Mill Creek and surrounding areas who need such services may not be able to get help, which directly impacts our community. AWC actively supports and will engage with those seeking to direct resources to address these challenges and will collaborate with the state, counties, and providers to find ways to deliver support services in the most effective manner.

3. Enhance economic development tools and programs that foster business development in cities

Economic development opportunities vary greatly across the state. Some communities have commercial or industrial areas that have deteriorated or lack the needed infrastructure for critical development, and others lack access to adequate broadband services. AWC supports expansion of current programs and funding, and will engage key legislators and stakeholders to identify tools that can help foster vital economies in all areas of the state. The City of Mill Creek is strategically integrating land use policy, building code, roadway connectivity and access to public transportation as tools to enhance economic development. Having additional support through state programs and funding will enhance our economic development opportunities.

4. Preserve state-shared revenues with cities and increase law enforcement training funds

The 2017-19 state operating budget continued to fund traditional shared revenues, such as liquor revenues and municipal criminal justice assistance, at the levels provided in recent years. However, funding that was committed in the last several capital budgets has been diverted to other state projects. As a result, funding provided by the state in the last few years to keep the number of law enforcement training classes at an acceptable level has been on an emergency basis. There is a significant need to ensure these funds are preserved for their intended use. As the Legislature considers a supplemental budget, AWC is encouraging the provision of additional funding for four additional Basic Law Enforcement Academy classes during the biennium to ensure that new recruits receive training as quickly as possible.

CITY MANAGER RECOMMENDATION:

N/A

ATTACHMENTS:

N/A

Respectfully Submitted:

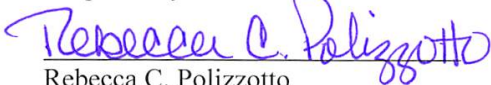

Rebecca C. Polizzotto
City Manager



Agenda Item # D

Meeting Date: November 28, 2017

CITY COUNCIL AGENDA SUMMARY

City of Mill Creek, Washington

AGENDA ITEM: MILL CREEK SPORTS PARK – FREEDOM FIELD REHABILITATION PROJECT SUMMARY

PROPOSED MOTION: Authorize the City Manager to execute an interlocal agreement between Snohomish County and the City of Mill Creek for park project funding.

KEY FACTS AND INFORMATION SUMMARY:

In 2016, the City submitted a grant application to the Washington State Recreation and Conservation Office (RCO) to receive a \$250,000 grant to be used towards rehabilitation of the existing Mill Creek Sports Park – Freedom Field complex. The scope of the project is replacement of the 64,050 square feet of field turf that is currently 13 years old.

The park opened in 2004 and serves 3,825 youth annually. The field is rented 2,661 hours over the course of 330 days by local youth sports organizations. The average recommended life span of field turf is 8 to 10 years. The new field turf will have embedded baseball, softball and soccer lines that reduce staff time needed to manually paint the lines each sports season throughout the year.

The project also includes updating the current metal halide lighting system to brand new LED lighting throughout the park. The LED lighting upgrade will reduce the continued expense of the City hiring a professional electric company to replace the current light bulbs every six years. LED lighting has a vendor warranty of 20 years. The third component of the project will be adding an ADA accessible gate on the third base line, off the main parking lot for ease of access for all community members.

In 2017, the City received notification from the RCO office that the “Mill Creek Sports Park – Rehabilitation Project” rated sixth out of seventeen submissions to the Youth Athletic Fund, (YAF) RCO grant fund. This rating guarantees the City will receive the \$250,000 in requested grant funding once the state of Washington passes a capital budget. The City also will receive a \$26,000 rebate from Snohomish County PUD for updating the field lighting to LED, reducing the overall lighting costs and power consumption of the overall facility.

In addition, Snohomish County Councilmember Terry Ryan presented a check to the City of Mill Creek at the April 4, 2017, Council meeting for \$100,000 toward the project. The \$100,000 is part of an Inter-Local Agreement with the County and is being distributed out of the counties 2017 – 2022 Capital Improvement Plan.

The additional \$399,000 of project funding will come from the City’s Capital Improvement Program. The City’s current 2017-2018 Biennial Budget lists \$775,000 for the overall project expense.

City Council Agenda Summary
Page 2

The City is currently waiting for the State of Washington to pass a capital budget to receive the \$250,000. Under current grant criteria only certain aspects of the overall project such as design and engineering can be completed prior to signing final paperwork with the RCO office. Staff is hopeful that the state will pass a capital budget within the first few weeks of the 2018 legislative session.

CITY MANAGER RECOMMENDATION:

N/A

ATTACHMENTS:

Respectfully Submitted:

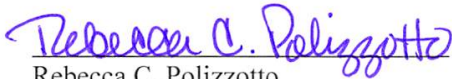

Rebecca C. Polizzotto
City Manager

INTERLOCAL AGREEMENT BETWEEN SNOHOMISH COUNTY AND THE CITY OF MILL CREEK FOR PARK PROJECT FUNDING

This INTERLOCAL AGREEMENT BETWEEN SNOHOMISH COUNTY AND THE CITY OF MILL CREEK FOR PARK PROJECT FUNDING (this "Agreement"), is made and entered into this ___ day of _____, 2017, by and between SNOHOMISH COUNTY, a political subdivision of the State of Washington (the "County"), and the CITY OF MILL CREEK, a Washington municipal corporation (the "City"), pursuant to Chapter 39.34 RCW.

RECITALS

A. The 2015 General Policy Plan, Parks and Recreation, Goal PR 1, includes a component to provide recreation services to Snohomish County's residents in the most effective and efficient way possible; and

B. The County Executive and the County Council have determined that it is consistent with the General Policy Plan and is in the public interest of County residents to participate in joint undertakings with local municipalities to increase recreational opportunities and facility capacity; and

C. The County Council approved Ordinance 16-094, dated on November 14, 2016, which adopted the 2017-2022 Capital Improvement Program as part of the Snohomish County Capital Facilities Plan; and

D. The Council adopted Priority Package Detail included funding for certain capital improvement projects, including funding to the City of Mill Creek, Mill Creek Sports Park, in an amount up to One Hundred Thousand and no/100 Dollars (\$100,000.00) in REET 2 funds (the "Funds") for the purpose of helping with the final funding required to resurface the utilized sports field and lighting, Package ID # 182; and

E. Pursuant to this Agreement and Chapter 39.34 RCW, the City wishes to accept the above-described Funds from the County; and

AGREEMENT

NOW, THEREFORE, in consideration of the respective agreements set forth below and for other good and valuable consideration, the receipt and sufficiency of which are hereby acknowledged, the County and the City agree as follows:

1. Purpose of Agreement.

This Agreement is authorized by and entered into pursuant to Chapter 39.34 RCW. The purpose and intent of this Agreement is to define the responsibilities of the County and the City as they relate to the County's provision of Funds to the City for improvements to the Mill Creek Sports Park (the "Project") located at 13903 North Creek

Drive, Mill Creek, WA 98012. The Project funding will contribute to the rehabilitation of an existing active play facility with turf replacement, improved lighting system and adding an ADA gate to the existing field fencing. The design elements and location for the Project is attached hereto and incorporated herein as Schedule A.

2. Effective Date and Duration.

This Agreement shall not take effect unless and until it has been duly executed by both parties and either filed with the County Auditor or posted on the County's Interlocal Agreements website. This Agreement shall remain in effect through December 30, 2020, unless earlier terminated pursuant to the provisions of Section 12 below, PROVIDED HOWEVER, that each party's obligations after December 31, 2017, are contingent upon local legislative appropriation of necessary funds for this specific purpose in accordance with applicable law.

3. Administrators.

Each party to this Agreement shall designate an individual (an "Administrator"), who may be designated by title or position, to oversee and administer such party's participation in this Agreement. The parties' initial Administrators shall be the following individuals:

County's Initial Administrator:

Tom Teigen, Director
Snohomish County Parks and
Recreation Department
6705 Puget Park Drive
Snohomish, Washington 98296
(425) 388-6617 phone
(425) 388-6645 facsimile
Tom.Teigen@snoco.org

City's Initial Administrator:

Rebecca Polizzotto
City Manager
City of Mill Creek
15728 Main Street
Mill Creek, WA 98012
(425) 921-5724 phone
rebeccap@cityofmillcreek.com

Either party may change its Administrator at any time by delivering written notice of such party's new Administrator to the other party.

4. Project Performance.

4.1 Certification of Real Property Interest. The City certifies to the County that the City owns the real property or easements upon which the Project shall be executed and additional real property or easements are not needed to complete the Project.

4.2 City's Financial Commitment. The City certifies to the County that the City has monies sufficient to match any funding provided by the County to the City under the terms of this Agreement and will have sufficient monies to complete the Project by

the Project deadline identified in Section 4.3 below (the “City’s Financial Commitment”).

4.3 Project Deadline. On or before December 30, 2020, the City shall complete the Project. In executing the Project, the City shall obtain and, upon request, provide the County with copies of all permits necessary to complete the Project.

4.4 Recognition of County as Financial Sponsor. The City shall recognize the County as a financial sponsor of the Project as follows:

4.4.1 Upon completion of the Project or dedication of the Park Property, whichever comes first, the City shall install at the Park Property a plaque in a form approved by the County that indicates that the County is a financial sponsor of the Project;

4.4.2 The City shall invite the County to all events promoting the Project or Park Property and recognize the County at all such events as a financial sponsor of the Project;

4.4.3 The City shall recognize the County as a financial sponsor in all brochures, banners, posters, and other promotional material related to the Project.

4.5 Project Maintenance. The City shall be responsible for on-going capital improvements to, and maintenance of, the Project and Park Property. The County makes no commitment to support the Project or Park Property beyond what is provided for in this Agreement and assumes no obligation for future support of the Project or Park Property except as expressly set forth in this Agreement.

4.6 Availability to County Residents. The City shall make the Park Property available to all County residents on the same terms as to residents of the City.

5. Invoicing and Payment.

5.1 Invoicing. Prior to December 30, 2020, the City shall submit to the County an invoice requesting disbursement of the Funds for the Project. The invoice shall provide line item detail for materials, labor and overhead and include any documentation requested by the County, including but not limited to documentation as to what amounts have been spent by the City on the Project.

5.2 Payment. Unless the County delivers to the City written notice disputing the amount of a particular line item, within twenty (20) working days of receipt from the City of an invoice properly submitted to the County pursuant to Section 5.1, the County shall remit to the City an amount not to exceed One Hundred Thousand and no/100 Dollars (\$100,000.00).

5.3 No Overpayments. In the event that the Project is completed for less than the combined total of the Funds and the City’s Financial Commitment, the County shall

remit to the City an amount of Funds equal to the difference between the City's Financial Commitment and the total cost of the Project. In no case shall the City retain Funds which it does not utilize in the Project or that it utilizes in the Project without first exhausting the City's Financial Commitment. Should an overpayment occur, the County shall give written notice to the City of the overpayment, and within thirty (30) days of the notice of overpayment the City shall return to the County the overpaid Funds plus interest at the rate of twelve percent (12%) per annum beginning thirty (30) days from the date of the notice of overpayment.

5.4 Accounting. The City shall maintain a system of accounting and internal controls that complies with generally accepted accounting principles and governmental accounting and financial reporting standards and provisions concerning preservation and destruction of public documents in accordance with applicable laws, including Chapter 40.14 RCW.

5.5 Recordkeeping. The City shall maintain adequate records to support billings. The records shall be maintained by the City for a period of five (5) years after completion of this Agreement. The County, or any of its duly authorized representatives, shall have access to books, documents, or papers and records of the City relating to this Agreement for purposes of inspection, audit, or the making of excerpts or transcripts.

6. Independent Contractor.

The City will perform all work associated with the Project as an independent contractor and not as an agent, employee, or servant of the County. The City shall be solely responsible for control, supervision, direction and discipline of its personnel, who shall be employees and agents of the City and not the County. The County shall only have the right to ensure performance.

7. Indemnification/Hold Harmless.

The City shall assume the risk of, be liable for, and pay all damage, loss, costs and expense of any party arising out of the activities under this Agreement and all use of any improvements it may place on the Property. The City shall hold harmless, indemnify and defend the County, its officers, elected and appointed officials, employees and agents from and against all claims, losses, lawsuits, actions, counsel fees, litigation costs, expenses, damages, judgments, or decrees by reason of damage to any property or business and/or any death, injury or disability to or of any person or party, including but not limited to any employee, arising out of or suffered, directly or indirectly, by reason of or in connection with the acquisition or use of the Park Property and this Agreement; PROVIDED, that the above indemnification does not apply to those damages solely caused by the negligence or willful misconduct of the County, its elected and appointed officials, officers, employees or agents.

8. Liability Related to City Ordinances, Policies, Rules and Regulations.

In executing this Agreement, the County does not assume liability or responsibility for or in any way release the City from any liability or responsibility which arises in whole or in part from the existence or effect of City ordinances, policies, rules or regulations. If any cause, claim, suit, action or administrative proceeding is commenced in which the enforceability and/or validity of any such City ordinance, policy, rule or regulation is at issue, the City shall defend the same at its sole expense and, if judgment is entered or damages are awarded against the City, the County, or both, the City shall satisfy the same, including all chargeable costs and reasonable attorney's fees.

9. Insurance.

The City shall procure and maintain for the duration of this Agreement, insurance against claims for injuries to persons or damages to property which may arise from, or in connection with exercise of the rights and privileges granted by this Agreement, by the City, his agents, representatives, employees/subcontractors. The cost of such insurance shall be paid by the City.

9.1 Minimum Scope and Limits of Insurance. General Liability: Insurance Services Office Form No. CG 00 01 Ed. 11-88, covering COMMERCIAL GENERAL LIABILITY with limits no less than \$1,000,000 combined single limit per occurrence for bodily injury, personal injury, and property damage.

9.2 Other Insurance Provisions. Coverage shall be written on an "Occurrence" form. The insurance policies required in this Agreement are to contain or be endorsed to contain the County, its officers, officials, employees, and agents as additional insureds as respects liability arising out of activities performed by or on behalf of the City in connection with this Agreement.

9.3 Verification of Coverage. The City shall furnish the County with certificate(s) of insurance and endorsement(s) required by this Agreement.

10. Compliance with Laws.

In the performance of its obligations under this Agreement, each party shall comply with all applicable federal, state, and local laws, rules and regulations.

11. Default and Remedies.

11.1 Default. If either the County or the City fails to perform any act or obligation required to be performed by it hereunder, the other party shall deliver written notice of such failure to the non-performing party. The non-performing party shall have twenty (20) days after its receipt of such notice in which to correct its failure to perform the act or obligation at issue, after which time it shall be in default ("Default") under this Agreement; provided, however, that if the non-performance is of a type that could not reasonably be cured within said twenty (20) day period, then the non-performing party

shall not be in Default if it commences cure within said twenty (20) day period and thereafter diligently pursues cure to completion.

11.2 Remedies. In the event of a party's Default under this Agreement, then after giving notice and an opportunity to cure pursuant to Section 11.1 above, the non-Defaulting party shall have the right to exercise any or all rights and remedies available to it in law or equity.

12. Early Termination.

12.1 30 Days' Notice. Except as provided in Sections 12.2 and 12.3 below, either party may terminate this Agreement at any time, with or without cause, upon not less than thirty (30) days advance written notice to the other party. The termination notice shall specify the date on which the Agreement shall terminate.

12.2 Lack of Funding. This Agreement is contingent upon governmental funding and local legislative appropriations. In the event that funding from any source is withdrawn, reduced, limited, or not appropriated after the effective date of this Agreement, this Agreement may be terminated by either party immediately by delivering written notice to the other party. The termination notice shall specify the date on which the Agreement shall terminate.

12.3 Termination for Breach. In the event that the City fails to complete the Project by December 30, 2020, commits a Default as described in Section 11, or otherwise fails to appropriate the funds necessary to complete the Project, the County may terminate this Agreement immediately by delivering written notice to the City. Within thirty (30) days of such early termination, the City shall return to the County all Funds previously disbursed from the County to the City for the Project plus interest at the rate of twelve percent (12%) per annum beginning thirty (30) days from the date of early termination.

13. Dispute Resolution.

In the event differences between the parties should arise over the terms and conditions or the performance of this Agreement, the parties shall use their best efforts to resolve those differences on an informal basis. If those differences cannot be resolved informally, the matter may be referred for mediation to a mediator mutually selected by the parties. If mediation is not successful or if a party waives mediation, either of the parties may institute legal action for specific performance of this Agreement or for damages. The prevailing party in any legal action shall be entitled to a reasonable attorneys' fee and court costs.

14. Notices.

All notices required to be given by any party to the other party under this Agreement shall be in writing and shall be delivered either in person, by United States

mail, or by electronic mail (email) to the applicable Administrator or the Administrator's designee. Notice delivered in person shall be deemed given when accepted by the recipient. Notice by United States mail shall be deemed given as of the date the same is deposited in the United States mail, postage prepaid, and addressed to the Administrator, or their designee, at the addresses set forth in Section 3 of this Agreement. Notice delivered by email shall be deemed given as of the date and time received by the recipient.

15. Miscellaneous.

15.1 Entire Agreement; Amendment. This Agreement constitutes the entire agreement between the parties regarding the subject matter hereof, and supersedes any and all prior oral or written agreements between the parties regarding the subject matter contained herein. This Agreement may not be modified or amended in any manner except by a written document executed with the same formalities as required for this Agreement and signed by the party against whom such modification is sought to be enforced.

15.2 Conflicts between Attachments and Text. Should any conflicts exist between any attached exhibit or schedule and the text or main body of this Agreement, the text or main body of this Agreement shall prevail.

15.3 Governing Law and Venue. This Agreement shall be governed by and enforced in accordance with the laws of the State of Washington. The venue of any action arising out of this Agreement shall be in the Superior Court of the State of Washington, in and for Snohomish County. In the event that a lawsuit is instituted to enforce any provision of this Agreement, the prevailing party shall be entitled to recover all costs of such a lawsuit, including reasonable attorney's fees.

15.4 Interpretation. This Agreement and each of the terms and provisions of it are deemed to have been explicitly negotiated by the parties, and the language in all parts of this Agreement shall, in all cases, be construed according to its fair meaning and not strictly for or against either of the parties hereto. The captions and headings in this Agreement are used only for convenience and are not intended to affect the interpretation of the provisions of this Agreement. This Agreement shall be construed so that wherever applicable the use of the singular number shall include the plural number, and vice versa, and the use of any gender shall be applicable to all genders.

15.5 Severability. If any provision of this Agreement or the application thereof to any person or circumstance shall, for any reason and to any extent, be found invalid or unenforceable, the remainder of this Agreement and the application of that provision to other persons or circumstances shall not be affected thereby, but shall instead continue in full force and effect, to the extent permitted by law.

15.6 No Waiver. A party's forbearance or delay in exercising any right or remedy with respect to a Default by the other party under this Agreement shall not

constitute a waiver of the Default at issue. Nor shall a waiver by either party of any particular Default constitute a waiver of any other Default or any similar future Default.

15.7 No Assignment. This Agreement shall not be assigned, either in whole or in part, by either party without the express written consent of the other party, which may be granted or withheld in such party's sole discretion. Any attempt to assign this Agreement in violation of the preceding sentence shall be null and void and shall constitute a Default under this Agreement.

15.8 Warranty of Authority. Each of the signatories hereto warrants and represents that he or she is competent and authorized to enter into this Agreement on behalf of the party for whom he or she purports to sign this Agreement.

15.9 No Joint Venture. Nothing contained in this Agreement shall be construed as creating any type or manner of partnership, joint venture or other joint enterprise between the parties.

15.10 No Separate Entity Necessary. The parties agree that no separate legal or administrative entities are necessary to carry out this Agreement.

15.11 Ownership of Property. Except as expressly provided to the contrary in this Agreement, any real or personal property used or acquired by either party in connection with its performance under this Agreement will remain the sole property of such party, and the other party shall have no interest therein.

15.12 No Third Party Beneficiaries. This Agreement and each and every provision hereof is for the sole benefit of the City and the County. No other persons or parties shall be deemed to have any rights in, under or to this Agreement.

15.13 Execution in Counterparts. This Agreement may be executed in two or more counterparts, each of which shall constitute an original and all of which shall constitute one and the same agreement.

[The remainder of this page is intentionally left blank.]

IN WITNESS WHEREOF, the parties have executed this Agreement as of the date first above written.

COUNTY:

Snohomish County, a political subdivision of the State of Washington

CITY:

City of Mill Creek, a Washington municipal corporation

By _____
Name: Dave Somers
Title: Executive

By _____
Name: Rebecca Polizzotto
Title: City Manager

Attest/Authenticate

By _____
Name: Peggy Lauerman
Title: City Clerk

Approved as to Form:

 10/27/17
Deputy Prosecuting Attorney

Approved as to Form:

Office of the City Attorney

Schedule A

INTERLOCAL AGREEMENT BETWEEN SNOHOMISH COUNTY AND THE CITY OF MILL
CREEK FOR PARK PROJECT FUNDING

10 of 14

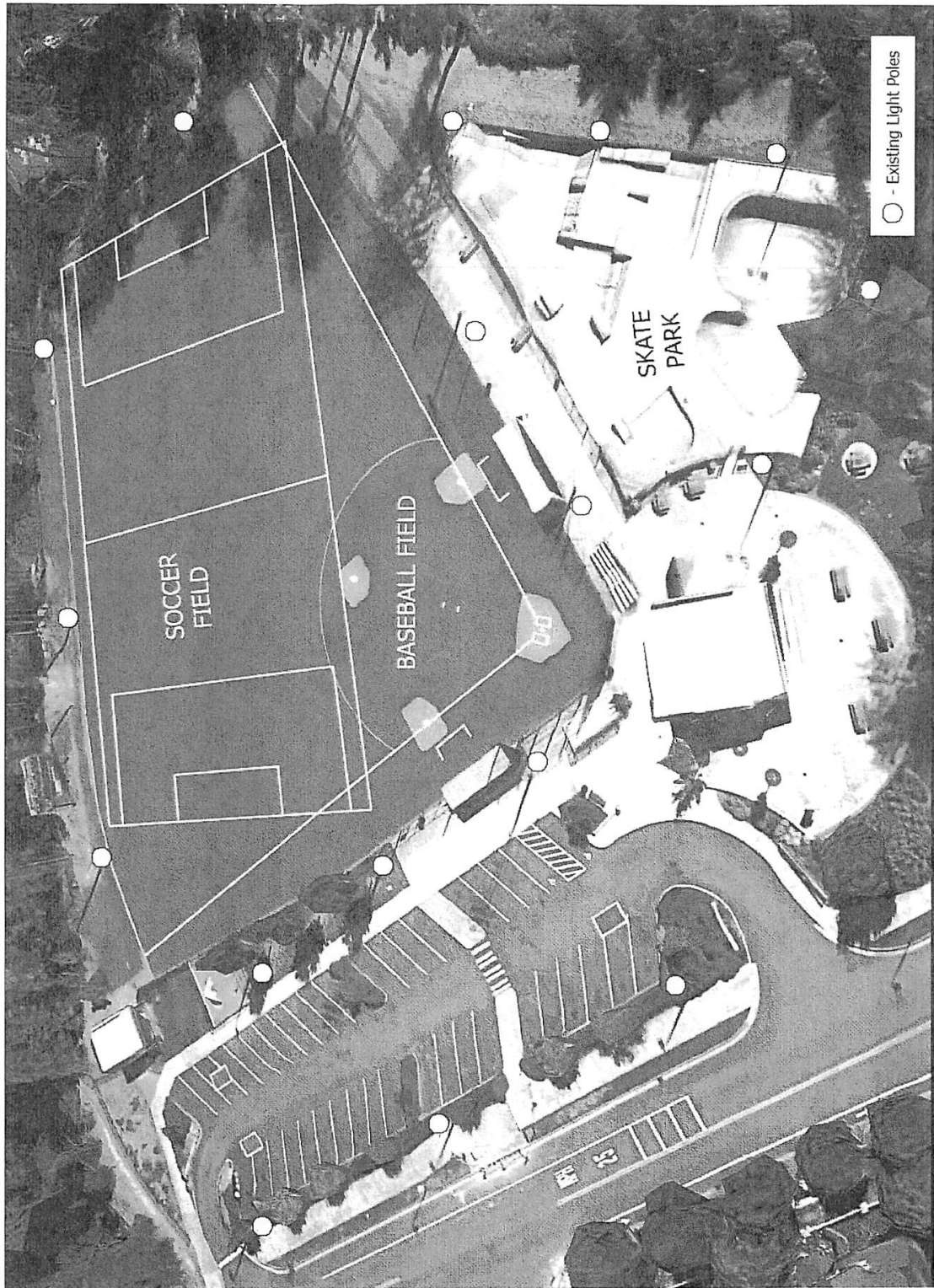

INTERLOCAL AGREEMENT BETWEEN SNOHOMISH COUNTY AND THE CITY OF MILL CREEK FOR PARK PROJECT FUNDING

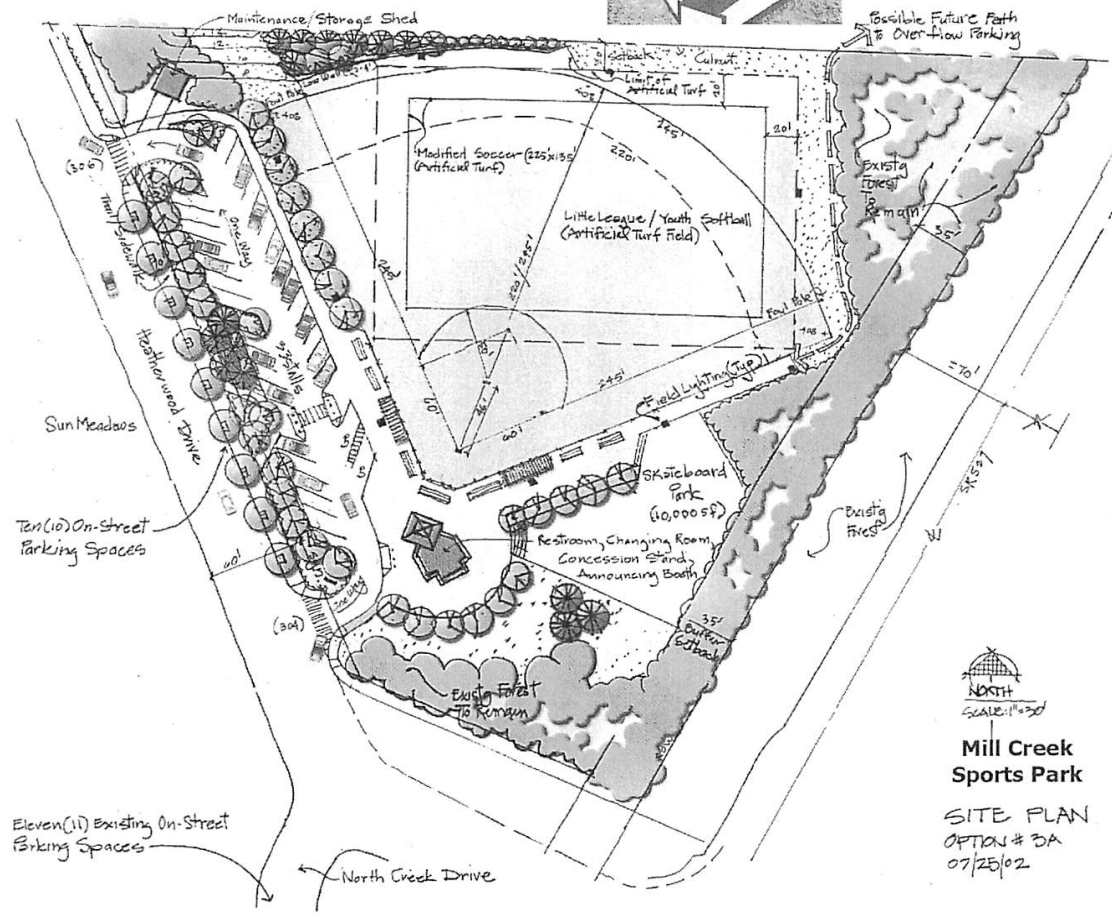
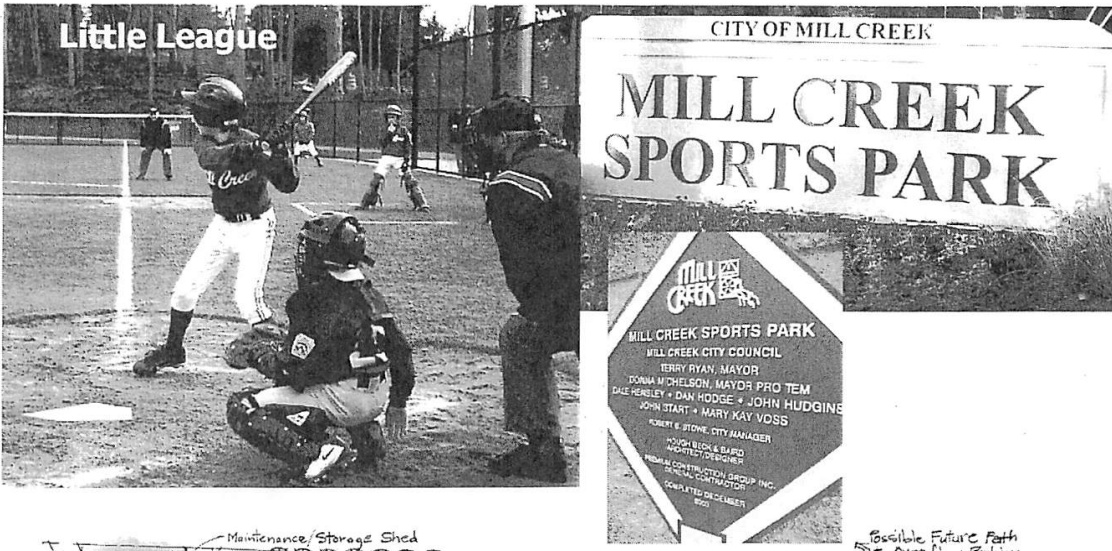

INTERLOCAL AGREEMENT BETWEEN SNOHOMISH COUNTY AND THE CITY OF MILL CREEK FOR PARK PROJECT FUNDING

New LED Lighting Fixtures Mounting on Existing Light Poles

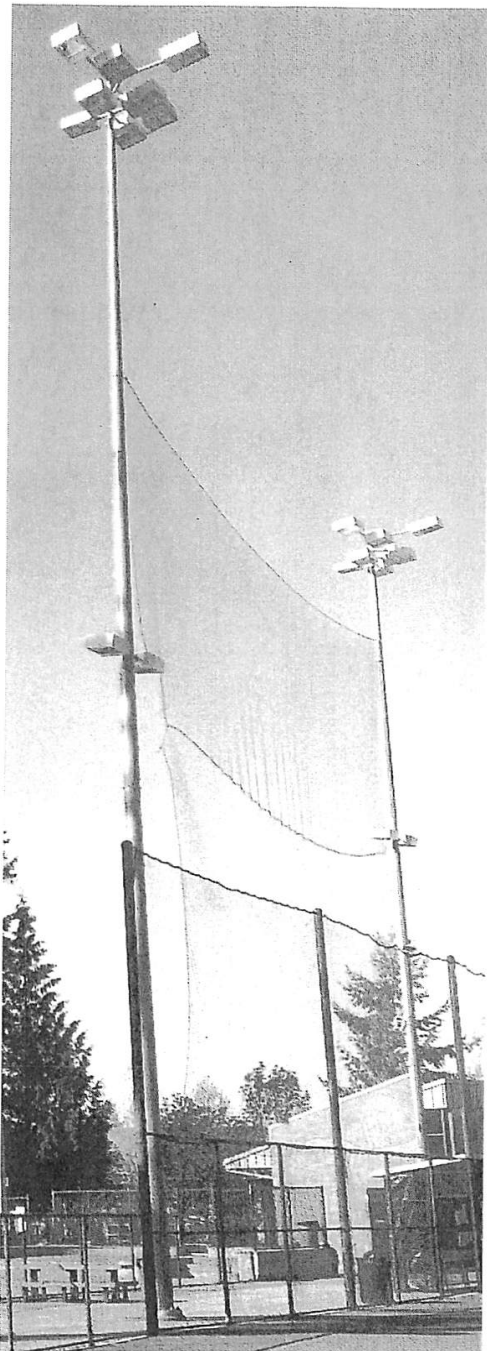

Current Light Poles

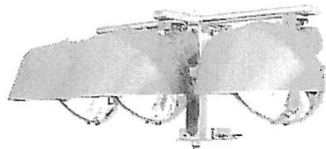

New Fixtures

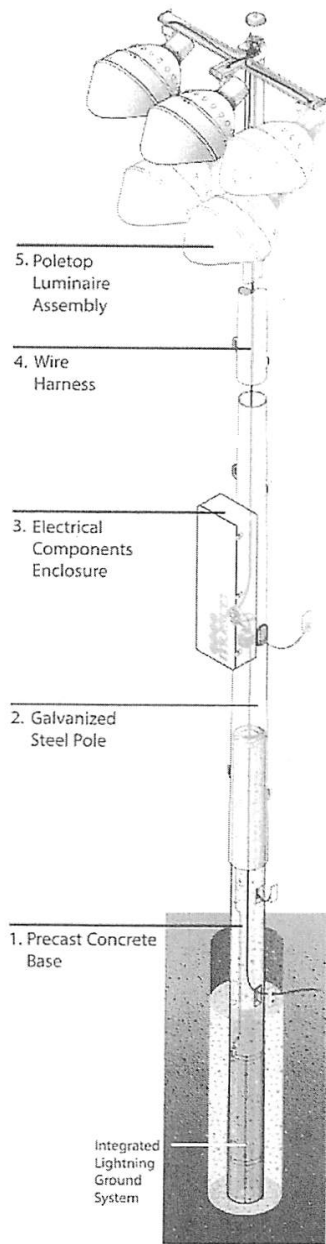

New Hardware on Current Poles

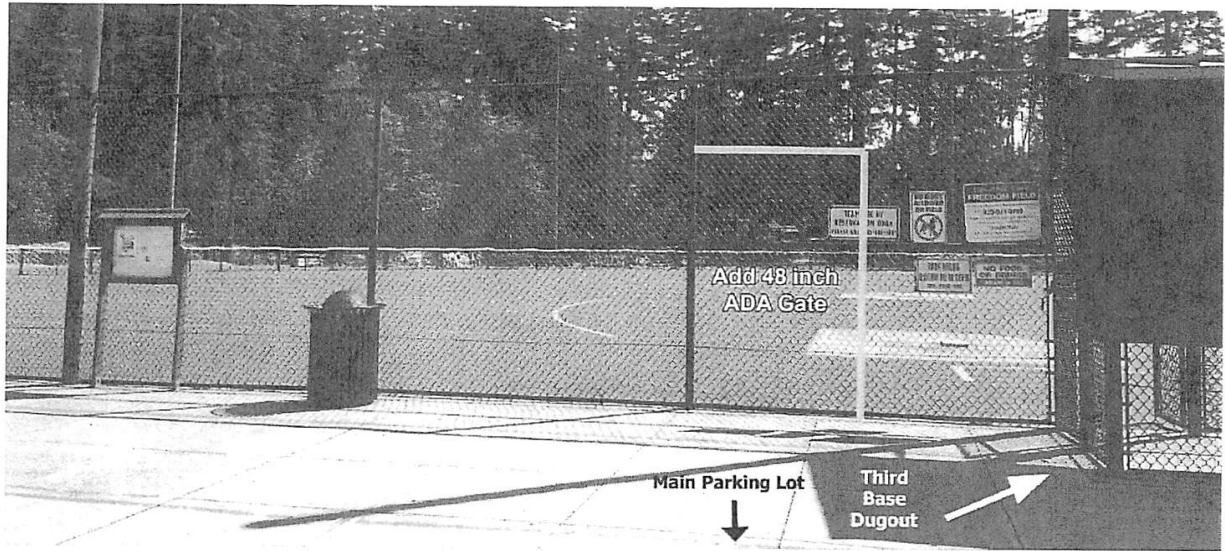



Date: November 28, 2017

A/P Check Batches		
Dated	Check Numbers	Amount
11/08/2017	ACH-CPSM	\$9,270.00
11/15/2017	57778-57853	\$1,019,548.60
11/20/2017	ACH-CPSM	\$13,600.00
11/20/2017	ACH-Union 76 Fleet-Sept	\$4,456.46
Total		\$1,046,875.06

Voided Checks	
Numbers	Explanation

CLAIMS APPROVAL

We, the undersigned Finance/Audit Committee of the City of Mill Creek, recommend approval of check numbers 57778 through 57853, and ACH/Wire in the amount of \$1,046,875.06.

We recommend approval of the above stated amount with the following exceptions:

Councilmember

Councilmember

Finance Director

City Manager

F:\DATA\EXECUTIVE\WP\FORMS\FIN\Voucher Approval1.doc

RptBatchSumViewForm

Page 1 of 1

ACH Cash Pro Online
City of Mill Creek

Report Date: 11/07/2017
Report Time: 01:00:12 PM

Batch Summary Report by ID Number

Company Name: City of Mill 01 Effective Date: 11/08/2017
 ACH ID: 2911225895 Batch Sequence: 1
 Application Name: CCD Payments and Collections Database Name: CPSM
 Batch Status: Released Created By: SANKOTTKE
 Released By: PLAUERMAN

Name	ID	Amount	D/C	Bank ID	Account #	Acct Type	Trace #
CPSM CENTER FOR PUBLIC	CPSM	\$9,270.00	C	052000113	9856252680	C	

	Total Amount in Batch	Total Count in Batch
Debits	\$0.00	0
Credits	\$9,270.00	1
Prenotes	\$0.00	0

	Grand Total Amount	Grand Total Count
Debits	\$0.00	0
Credits	\$9,270.00	1
Prenotes	\$0.00	0

RptBatchSumViewForm

Page 1 of 1

ACH Cash Pro Online
City of Mill Creek

Report Date: 11/17/2017
Report Time: 05:37:54 PM

Batch Summary Report by ID Number

Company Name: City of Mill 01 Effective Date: 11/20/2017
 ACH ID: 2911225895 Batch Sequence: 2
 Application Name: CCD Payments and Collections Database Name: CPSM
 Batch Status: Released Created By: SANKOTTKE
 Released By: PLAUERMAN

Name	ID	Amount	D/C	Bank ID	Account #	Acct Type	Trace #
CPSM CENTER FOR PUBLIC	CPSM	\$13,600.00	C	052000113	9856252680	C	

	Total Amount in Batch	Total Count in Batch
Debits	\$0.00	0
Credits	\$13,600.00	1
Prenotes	\$0.00	0

	Grand Total Amount	Grand Total Count
Debits	\$0.00	0
Credits	\$13,600.00	1
Prenotes	\$0.00	0

RptBatchSumViewForm

Page 1 of 1

ACH Cash Pro Online
City of Mill Creek

Report Date: 11/17/2017
Report Time: 05:37:10 PM

Batch Summary Report by ID Number

Company Name: City of Mill 01 Effective Date: 11/20/2017
 ACH ID: 2911225895 Batch Sequence: 1
 Application Name: CCD Payments and Collections Database Name: 76
 Batch Status: Released Created By: SANKOTTKE
 Released By: PLAUERMAN

Name	ID	Amount	D/C	Bank ID	Account #	Acct Type	Trace #
76 FLEET WEX BANK	0201-00-1059153	\$4,456.46	C	071000288	4539508	C	

	Total Amount in Batch	Total Count in Batch
Debits	\$0.00	0
Credits	\$4,456.46	1
Prenotes	\$0.00	0

	Grand Total Amount	Grand Total Count
Debits	\$0.00	0
Credits	\$4,456.46	1
Prenotes	\$0.00	0

Accounts Payable

Checks by Date - Detail by Check Date

User: jodieg
 Printed: 11/20/2017 10:30 AM



Check No	Vendor No Invoice No	Vendor Name Description	Check Date Reference	Void Checks	Check Amount
57778	911SUPPL IN-10593	911 Supply Inc 1 Pr Boots-L Pigott-Per AFSCME Agreement	11/15/2017		153.99
				Total for Check Number 57778:	0.00 153.99
57779	AFSCME October	WSCCCE, AFSCME, AFL-CIO Union Dues-AFSCME-Oct	11/15/2017		1,219.86
				Total for Check Number 57779:	0.00 1,219.86
57780	AGRII 1638	AGRII Party & Events Tent Rental 11/11-Veterans Day	11/15/2017		579.60
				Total for Check Number 57780:	0.00 579.60
57781	ALEXPRCO 52905	Alexander Printing Company Inc #10 Window-Logo Envelopes	11/15/2017		680.62
				Total for Check Number 57781:	0.00 680.62
57782	ALLBATRY 800-10025863	All Battery Sales & Service Battery for Jeep Cherokee - Car7	11/15/2017		103.51
				Total for Check Number 57782:	0.00 103.51
57783	ANARESIN 1703087	Analytical Resources, Inc Street Sweeping - Disposal Testing	11/15/2017		560.00
				Total for Check Number 57783:	0.00 560.00
57784	AWC-RISK 55923	AWC-Risk Management Service Agency Cancellation Fee-2017 Member Expo-L Orlando	11/15/2017		75.00
				Total for Check Number 57784:	0.00 75.00
57785	BANKCR16	Bank of America	11/15/2017		
	1	Survey Tape-Marking Landscaping			9.01
	2	MC Rotary Mtg 10/11-T Rogers			17.00
	3	Parking 10/12-PAC Meeting-T Rogers			6.00
	4	MC Rotary Mtg 10/18-T Rogers			17.00
	5	MC Rotary Mtg 10/25-T Rogers			17.00
	6	WSAPT 2017 Special Exam Admin Application-			199.00
				Total for Check Number 57785:	0.00 265.01
57786	BELLT	Troy Bell	11/15/2017		
	1	Breakfast 9/30-T Bell-Director of PW&Dev Svc:			0.98
	10	Dinner 9/28-T Bell-Director of PW&Dev Sves C			16.00
	11	Dinner 9/27-T Bell-Director of PW&Dev Sves C			24.00
	12	Parking 9/30-T Bell-Director of PW&Dev Sves t			36.00
	13	Rental Car 9/27-9/30-T Bell-Director of PW&Dc			119.59

AGENDA ITEM #E.

Check No	Vendor No Invoice No	Vendor Name Description	Check Date Reference	Void Checks	Check Amount
14		Airfare 9/27-T Bell-Director of PW&Dev Svcs C			146.80
15		Airfare 9/30-T Bell-Director of PW&Dev Svcs C			146.80
16		Lodging 9/27-9/30-T Bell-Director of PW&Dev			290.87
2		Lunch 9/27-T Bell-Director of PW&Dev Svcs C			3.69
3		Mileage 9/29-T Bell-Director of PW&Dev Svcs			4.32
4		Lunch 9/27-T Bell-Director of PW&Dev Svcs C			5.46
5		Mileage 9/29-T Bell-Director of PW&Dev Svcs			5.50
6		Lunch 9/28-T Bell-Director of PW&Dev Svcs C			9.05
7		Lunch 9/29-T Bell-Director of PW&Dev Svcs C			9.90
8		Dinner 9/27-T Bell-Director of PW&Dev Svcs C			9.99
9		Dinner 9/29-T Bell-Director of PW&Dev Svcs C			5.09
				Total for Check Number 57786:	834.04
57787	BENEAD 1710515	Benefit Administration Co, LLC Section 125 Flexible Benefits Plan-Oct	11/15/2017		113.10
				Total for Check Number 57787:	113.10
57788	CIEDMOND RGG-170068	City of Edmonds Domestic Violence Coordinator-Nov	11/15/2017		954.90
				Total for Check Number 57788:	954.90
57789	CINTAS 460231591 460231591A 460240904 460240904A	Cintas Corporation Loc. #460 Floor Mat Service 10/13 Floor Mat Service 10/13 Floor Mat Service 10/27 Floor Mat Service 10/27	11/15/2017		84.97 49.55 84.97 49.55
				Total for Check Number 57789:	269.04
57790	CMHEAT B2017-0681 B2017-0681a	C M Heating Inc Refund B2017-0681 - Incorrect Parcel Number Refund B2017-0681 - Incorrect Parcel Number	11/15/2017		45.00 1.35
				Total for Check Number 57790:	46.35
57791	CODPUBCO 57819	Code Publishing Company MC Municipal Code-Editorial Supplement Code	11/15/2017		442.87
				Total for Check Number 57791:	442.87
57792	COMCAST 849831021072434	Comcast Internet for ITS 11/14-12/13	11/15/2017		106.40
				Total for Check Number 57792:	106.40
57793	CONSCONT L4BTV5VAB31717	Constant Contact, Inc. Constant Contact Subscription-6 Months	11/15/2017		536.58
				Total for Check Number 57793:	536.58
57794	DAYWIRE 448504	Day Wireless Systems (03) SMD Calibrations-11 Radar/LIDAR Units	11/15/2017		861.12
				Total for Check Number 57794:	861.12
57795	DEPTECOG 2018-WAR045529	Department of Ecology WSDOE Stormwater Permit #WAR045529	11/15/2017		14,627.34
				Total for Check Number 57795:	14,627.34

AGENDA ITEM #E.

Check No	Vendor No Invoice No	Vendor Name Description	Check Date Reference	Void Checks	Check Amount
57796	ELLITIRE	Elliott Tire & Service Inc	11/15/2017		
	080260	LOF, Fuel Filter - PW1			135.14
	080268	LOF, Engine Runability Diagnosis - PW7			158.82
	080284	LOF, Fuel Filter, Water Pump, Cooling System I			1,685.66
	080321	Replace Fuel Filters+LOF - PW10			422.44
	080333	LOF, Fuel Filter - Staff Car 3			440.22
	080333a	Discount-LOF, Fuel Filter - Staff Car 3			-124.64
	080346	New Battery - Car 41			419.21
Total for Check Number 57796:				0.00	3,136.85
57797	EVERGRML	Evergreen Maintenance Landscaping, LLC	11/15/2017		
	MC061 2017	Landscape Maintenance-Hillside Park-Oct			552.00
	MC062 2017	Landscape Maintenance-Heron Park-Oct			331.20
	MC063 2017	Landscape Maintenance-Nickel Creek Park-Oct			386.40
	MC064 2017	Landscape Maintenance-Buffalo Park-Oct			662.40
	MC065 2017	Landscape Maintenance-Highlands Park-Oct			993.60
	MC066 2017	Landscape Maintenance-Library Park-Oct			331.20
	MC067 2017	Landscape Maintenance-Public Library-Oct			772.80
	MC068 2017	Landscape Maintenance-City Hall South-Oct			772.80
	MC069 2017	Landscape Maintenance-North Creek Sports Parl			303.60
	MC070 2017	Landscape Maintenance-City Hall North-Oct			496.80
	MC071 2017	Landscape Maintenance-Cougar Park-Oct			496.80
	MC072 2017	Landscape Maintenance-Pine Meadow Park-Oct			772.80
	MC073 2017	Landscape Maintenance-ROW Medians-Oct			736.06
	MC074 2017	Landscape Maintenance-527 Medians-Oct			331.20
	MC075 2017	Landscape Maintenance-ROW Medians-Oct			1,349.37
	MC076 2017	Landscape Maintenance-Ditch #1 WSDOT-Oct			154.56
	MC077 2017	Landscape Maintenance-Ditch #2-Oct			154.56
	MC078 2017	Landscape Maintenance-Ditch #3-Oct			154.56
	MC079 2017	Landscape Maintenance-Pond #4-Oct			154.56
	MC080 2017	Landscape Maintenance-Pond #5-Oct			154.56
	MC081 2017	Landscape Maintenance-Pond #6-Oct			154.56
Total for Check Number 57797:				0.00	10,216.39
57798	FELDMAJ	Feldman & Lee, P.S.	11/15/2017		
	October 2017	Public Defender Contract Fee-Oct			8,750.00
Total for Check Number 57798:				0.00	8,750.00
57799	FONGJ	Jeffrey Fong	11/15/2017		
	6733	Photography: Digital Basic (Fall) 09/28-10/26 #1			318.50
Total for Check Number 57799:				0.00	318.50
57800	FOREPROM	Foremost Promotions	11/15/2017		
	399699	To Protect & Serve Crayon Pack-Police Commu			180.26
	399699A	Use Tax, To Protect & Serve Crayon Pack-Police			-16.98
Total for Check Number 57800:				0.00	163.28
57801	GRAYBAR	Graybar	11/15/2017		
	9300879737	2 Street Lights/LED Drivers			63.81
Total for Check Number 57801:				0.00	63.81
57802	GTHENORTH	Frontier	11/15/2017		
	425745697408189	CC Line/Security System Line 09/19-10/18			165.74
Total for Check Number 57802:				0.00	165.74

Check No	Vendor No Invoice No	Vendor Name Description	Check Date Reference	Void Checks	Check Amount
57803	HRSUSA 700373191008244	Capital One Commercial Refreshments-All Employee Meeting 10/05	11/15/2017		17.37
			Total for Check Number 57803:	0.00	17.37
57804	INTEGRA 251247	Allstream T-1 Monthly Chgs-Nov	11/15/2017		650.78
			Total for Check Number 57804:	0.00	650.78
57805	JOHNCLNR 2538	John's Cleaning Services Inc Uniform Dry Cleaning - Oct	11/15/2017		43.76
			Total for Check Number 57805:	0.00	43.76
57806	JOHNSOS 6725 6726	Stephen Johnson Beginner Basketball Basics: 5 Years-7 Years 10/ Beginner Basketball Basics: 8 Years-11 Years 10	11/15/2017		1,164.80 1,187.90
			Total for Check Number 57806:	0.00	2,352.70
57807	JRWENTRP 3891	JRW Enterprises Master Padlocks-MCSP	11/15/2017		132.48
			Total for Check Number 57807:	0.00	132.48
57808	KPFFCON 158803	KPFF Consulting Engineers Prof Serv 35th Ave Recon Proj 8/13-9/16	11/15/2017		3,246.25
			Total for Check Number 57808:	0.00	3,246.25
57809	KROESENS 47075 47128	Kroesen's Uniform Company Replace Zipper-Uniform Shirt-S Conner Ballistic Vest-T Bridgeman	11/15/2017		34.76 981.44
			Total for Check Number 57809:	0.00	1,016.20
57810	LESSCHW 39500352469	Les Schwab Tie Rod End, Ball Joint - PW5	11/15/2017		988.78
			Total for Check Number 57810:	0.00	988.78
57811	LEXNEXIS 3091176714	RELX Inc LexisNexis Monthly Chgs 10/01-10/31	11/15/2017		177.24
			Total for Check Number 57811:	0.00	177.24
57812	MAYBERM 6704 6708 6712	Mitch Mayberry Tiny Tiger Martial Arts (Fall 1) 09/08-10/27 #67 Tiger Martial Arts: Beginner (Fall 1) 09/08-10/27 Tiger Martial Arts: Colored (Fall 1) 09/08-10/27	11/15/2017		665.00 465.50 332.50
			Total for Check Number 57812:	0.00	1,463.00
57813	MMKIDS 6724	M & M Kids Sports LLC Tennis Classes for Kids (Sept) 09/20-11/08 #672	11/15/2017		1,097.25
			Total for Check Number 57813:	0.00	1,097.25
57814	OREILLY 2986-133203 2986-133229 2986-133404	O'Reilly Automotive Inc 2 Wiper Blades, Terminal Kit - PW2 Vehicle Supplies-Mini Bulbs, Car Wash Soap Spray Paint-9th Ave Bullard	11/15/2017		31.81 9.67 15.43

AGENDA ITEM #E.

Check No	Vendor No Invoice No	Vendor Name Description	Check Date Reference	Void Checks	Check Amount
	2986-135085	Aux Motor Belt - PW9 + PW10			43.70
	2986-135273	Fuel Filters - PW4 + PW5 + PW6			192.06
	2986-136320	35mm Socket-Fuel Filters			12.13
			Total for Check Number 57814:	0.00	304.80
57815	PACAIR 7093	Pacific Air Control, Inc. Boiler Repair-CHN	11/15/2017		358.25
			Total for Check Number 57815:	0.00	358.25
57816	PACLAB PEMC1065	PacLab Blood Draw Fee-DUI Case #2017-12856	11/15/2017		15.50
			Total for Check Number 57816:	0.00	15.50
57817	PACRIMC 10/2017	Pacific Rim Code Services, Inc Prof Service-Plan Reviews 10/10-10/12 5.5 Hrs	11/15/2017		330.00
			Total for Check Number 57817:	0.00	330.00
57818	PACTOP 1-T1033748	Pacific Topsoils, Inc. Pacific Garden Mulch-Heron Park Monument	11/15/2017		51.34
			Total for Check Number 57818:	0.00	51.34
57819	PAKOR 8026503	Pakor Inc 2 Cases Film-Passports	11/15/2017		625.58
			Total for Check Number 57819:	0.00	625.58
57820	PAWS Oct	PAWS Animals Brought to Shelter-Oct	11/15/2017		175.00
			Total for Check Number 57820:	0.00	175.00
57821	PERTEET 20160281.000-3	Perteet Inc Prof Serv NPDES Permit Review - 08/28-10/01	11/15/2017		2,818.75
			Total for Check Number 57821:	0.00	2,818.75
57822	PUTSCHEE 6698 6700 6702	Emilee Hope Putsche Ballet: Creative-10:30am (Fall) 10/14-11/04 #66 Ballet: Creative-11:15am (Fall) 10/14-11/04 #67 Ballet: Beginning 12:00pm (Fall) 10/14-11/04 #68	11/15/2017		560.00 350.00 280.00
			Total for Check Number 57822:	0.00	1,190.00
57823	RKSOLID 6716	Rock Solid Learning LLC Gems and Geodes (Fall) 11/04 #6716	11/15/2017		140.00
			Total for Check Number 57823:	0.00	140.00
57824	SCCFOA SCCFOA Mtg	Snohomish County Clerks And Finance Off SCCFOA Meeting 11/16-P Lauerman & J Gunde	11/15/2017		40.00
			Total for Check Number 57824:	0.00	40.00
57825	SCFIRDS MC-17-04	Sno County Fire District #7 Fire Interlocal Agreement - 4th Qtr	11/15/2017		883,603.65
			Total for Check Number 57825:	0.00	883,603.65

AGENDA ITEM #E.

Check No	Vendor No Invoice No	Vendor Name Description	Check Date Reference	Void Checks	Check Amount
57826	SDISTCRT	South District Court	11/15/2017		
	October 2017 October 2017A	Filing Fees SD Court - Oct Interpreter Costs - Oct			5,314.36 483.76
				Total for Check Number 57826:	0.00 5,798.12
57827	SEATIME2	The Seattle Times	11/15/2017		
	761595 765635	Ad "Assistant Director of Finance"-30 Day - 9/1. Ad "Assistant Director of Finance"-30 Day - 10/			500.00 500.00
				Total for Check Number 57827:	0.00 1,000.00
57828	SHERWILL	The Sherwin-Williams Co	11/15/2017		
	1404-8	5 Gal - Yellow Curb & Median Paint			46.00
				Total for Check Number 57828:	0.00 46.00
57829	SHI	SHI International Corp	11/15/2017		
	B07271814	SonicPoint Wireless Access Point			392.25
				Total for Check Number 57829:	0.00 392.25
57830	SILVERL	Silverlake Water District	11/15/2017		
	14112-27585	132nd + SR 527 Irrig 10/01-10/31			7.60
	14737-19068	Silver Crest Park 10/01-10/31			7.60
	17679-27345	Library Park 10/01-10/31			7.60
	17684-27596	15429 Bothell Way-Irrig 10/01-10/31			7.60
	24079-27593	Hillside Irrig 10/01-10/31			7.60
	32140-27632	13903 N Creek Dr-Irrig 10/01-10/31			7.60
	32141-27633	MCSP 10/01-10/31			73.45
	35995-27914	SR 527-Irrig 10/01-10/31			7.60
	35996-27914	14600 SR 527-Irrig 10/01-10/31			7.60
	35997-27914	13800 N SR 527-Irrig 10/01-10/31			7.60
	35998-27914	1600 SR 527-Irrig 10/01-10/31			7.60
	35999-27914	15200 SR 527-Irrig 10/01-10/31			7.60
	36000-27914	15100 N SR 527-Irrig 10/01-10/31			7.60
	36016-27914	SR 527 & Trillium Blvd-Irrig 10/01-10/31			7.60
	36025-27914	14600 SR 527-Irrig 10/01-10/31			7.60
	36026-27914	SR 527 & Dumas Rd-Irrig 10/01-10/31			7.60
	36365-27593	Dumas Rd Irrigation 10/01-10/31			22.30
	37034-30017	14721 12th Ave SE-Irrig 10/01-10/31			7.60
	37680-27914	0 33rd Dr & Northpointe Circle-Irrig 10/01-10/3			7.60
40191-27914	13315 45th Ave SE-Restroom 10/01-10/31			63.50	
				Total for Check Number 57830:	0.00 288.45
57831	SMARSH	Smarsh Inc	11/15/2017		
	INV00291228 INV00291228A	Text Archiving Platform-Verizon Monthly 10/01- Use Tax, Text Archiving Platform-Verizon Mont:			240.60 -7.80
				Total for Check Number 57831:	0.00 232.80
57832	SNDPUBIN	Sound Publishing Inc	11/15/2017		
	EDH784316	City Notice: 2018 Property Tax Levies			41.28
				Total for Check Number 57832:	0.00 41.28
57833	SNOCOC	Snohomish County Corrections	11/15/2017		
	2017-4019	Jail Service Fees-Aug			9,648.15
				Total for Check Number 57833:	0.00 9,648.15

AGENDA ITEM #E.

Check No	Vendor No Invoice No	Vendor Name Description	Check Date Reference	Void Checks	Check Amount
57834	SNOCOF	Snohomish County Finance	11/15/2017		
	1000450753	Interest 800MHZ-2nd Half 2017			2,253.89
	1000450753A	Principal 800MHZ-2nd Half 2017			28,685.93
Total for Check Number 57834:				0.00	30,939.82
57835	SNOCPW	Snohomish County Public Works	11/15/2017		
	1000450287	RR797-Aid Agreement-Crack Seal			1,255.28
	1000450288	RR7554-164th SE & 9th Ave SE - Sept			233.17
	1000450288A	RR7573-35th Ave SE & 148th SE - Sept			418.86
	1000450288B	RR7869-Mill Crk Blvd @ Main - Sept			291.42
Total for Check Number 57835:				0.00	2,198.73
57836	SNOCOSH1	Snohomish County Treasurer	11/15/2017		
	2017-4041	Inmate Medical Billing-Aug			11.94
Total for Check Number 57836:				0.00	11.94
57837	SNOCPUD	PUD No. 1 of Snohomish County	11/15/2017		
	2001-0143-4	Speed Radar Sign SHR:10/07-11/06			16.74
	2001-5445-8	2720 Seattle Hill Rd 10/07-11/06			16.74
	2007-4359-9	Street Lights-189 Lights-200W 10/01-10/31			1,736.91
	2013-5396-8	15728 Main St 10/05-11/02			1,529.45
	2013-6774-5	902-164th St SE 10/04-11/01			32.88
	2016-6351-5	14600 16th Ave SE 10/04-10/31			16.15
	2016-6928-0	Highlands Park 09/26-10/24			21.91
	2017-5296-1	Library Park 10/05-11/02			17.07
	2017-8113-5	2701 155th St SE 09/27-10/25			32.11
	2025-2921-0	Street Lights-386 Lights-100W 10/01-10/31			1,389.60
	2026-2439-1	Street Lights-841 Lights-100W 10/01-10/31			6,021.56
	2026-6749-9	2024 Seattle Hill Rd 10/07-11/07			37.42
	2027-6793-5	Street Lights-21 Lights-400W 10/01-10/31			312.90
	2029-0994-1	Street Lights-6 Lights-160W 10/01-10/31			28.98
	2029-2633-3	Hillside Park 09/28-10/25			15.12
	2029-5905-2	4842 SAC 10/05-11/02			71.75
	2030-2812-1	4560 SAC 10/04-10/31			50.68
	2032-5163-2	15510 Village Green Dr 09/27-10/25			15.66
	2033-4808-1	14810 35th Ave SE 10/07-11/06			68.96
	2033-8815-2	15429 Bothell Everett Hwy 10/05-11/02			25.92
	2047-1752-4	Street Lights-8 Lights-200W 10/01-10/31			47.68
	2047-1753-2	Street Lights-38 Lights-250W 10/01-10/31			285.38
	2047-1754-0	Street Lights-39 Lights-400W 10/01-10/31			441.48
	2050-8723-2	Street Lights-17 Lights-100W 10/01-10/31			52.87
	2054-9532-8	Street Lights-49 Lights-20W 10/01-10/31			17.15
	2203-1739-0	Street Lights-1 Light-240W 10/01-10/31			7.94
2206-1241-0	15601 22nd Ct SE 09/27-10/25	20.21			
2207-6351-0	13332 44th Ave SE 09/30-10/31	72.56			
2212-9311-1	Street Lights-1 Light-160W 10/01-10/31	5.18			
Total for Check Number 57837:				0.00	12,408.96
57838	STAPLEAD	Staples Advantage	11/15/2017		
	8047191363	Office Cleaning Supplies/2018 Wall Calendar			39.46
	8047191363A	Copy Paper			540.85
	8047191363B	Toner Cartridge-G Pfister			67.88
	8047191363C	11x17 Copy Paper, General Office Supplies-G H			135.09
	8047191363D	2018 Calendars 24x36 - J Kirk			27.37
Total for Check Number 57838:				0.00	810.65

AP Checks by Date - Detail by Check Date (11/20/2017 10:30 AM)

Page 7

Check No	Vendor No Invoice No	Vendor Name Description	Check Date Reference	Void Checks	Check Amount
57839	STARDMSV 0117200-IN 0117200-INA 0117200-INB 0117200-INC	Stardom Services Inc Janitorial Service-Oct-CHN Semi-Annual Window Cleaning-CHN Janitorial Service-Oct-GHS Semi-Annual Window Cleaning-CHS	11/15/2017		1,184.13 295.00 995.00 220.00
			Total for Check Number 57839:	0.00	2,694.13
57840	STERICYC 3004040047	Stericycle Inc Biomedical Waste Services-Monthly Fee	11/15/2017		10.36
			Total for Check Number 57840:	0.00	10.36
57841	TCSPANNA 79137	TC Span America 21 T-Shirts, 6-Sweatshirts-PW	11/15/2017		332.68
			Total for Check Number 57841:	0.00	332.68
57842	TLOLLC 839489	TransUnion Risk and Alternative Background/Identity Investigations-Oct	11/15/2017		25.00
			Total for Check Number 57842:	0.00	25.00
57843	TRAMMELI 6735	Lori Trammel Cupcake Class (Halloween Cakes) 10/28 #6735	11/15/2017		175.00
			Total for Check Number 57843:	0.00	175.00
57844	TRANSUN 10710851	Trans Union LLC Basic Service Monthly Fee-Credit Checks 09/26	11/15/2017		27.60
			Total for Check Number 57844:	0.00	27.60
57845	USBANK XXXXXXXX139	US.Bank NA - Custody Investment Custody Charges 10/01-10/31	11/15/2017		38.00
			Total for Check Number 57845:	0.00	38.00
57846	USIC 259040 259040a	USIC Locating Services, LLC 133 NC Locates/110 Ticket Locates/2 AH 133 NC Locates/110 Ticket Locates/2 AH	11/15/2017		1,318.52 1,318.52
			Total for Check Number 57846:	0.00	2,637.04
57847	UULC 7100164 7100164A	Utilities Underground Location Center On Call Location Service-114 Locates On Call Location Service-114 Locates	11/15/2017		73.53 73.53
			Total for Check Number 57847:	0.00	147.06
57848	VERIZON 9794850957	Verizon Wireless Access+Usage Chgs 09/21-10/20-City Cell Phon	11/15/2017		2,369.92
			Total for Check Number 57848:	0.00	2,369.92
57849	WASTDTR RE313ATB7091814	Washington State Dept. of Transportation Bridge Inspections - August 2017	11/15/2017		884.48
			Total for Check Number 57849:	0.00	884.48
57850	WASTPAT 118002959	Washington State Patrol Background Checks-Oct	11/15/2017		96.00

AGENDA ITEM #E.

Check No	Vendor No Invoice No	Vendor Name Description	Check Date Reference	Void Checks	Check Amount
			Total for Check Number 57850:	0.00	96.00
57851	WINSUPP 021448 00	Winsupply Company 2 PVC Cap-Repair Supplies	11/15/2017		1.58
			Total for Check Number 57851:	0.00	1.58
57852	WSDA 26026607	WA ST Dept of Agriculture Public Operator License+Testing Session Fee-J C	11/15/2017		116.00
			Total for Check Number 57852:	0.00	116.00
57853	ZUMAR 0191506	Zumar Industries, Inc. 5-No Parking Any Time Signs	11/15/2017		94.02
			Total for Check Number 57853:	0.00	94.02
			Total for 11/15/2017:	0.00	1,019,548.60
			Report Total (76 checks):	0.00	1,019,548.60



MINUTES

City Council Regular Meeting

6:00 PM - Tuesday, November 7, 2017

Council Chambers, 15728 Main Street, Mill Creek, WA 98012

Minutes are the official record of Mill Creek City Council meetings. Minutes document action taken at the council meeting, not what was said at the council meeting.

A recording of this City Council meeting can be found [here](#).

The agenda packet for this City Council meeting can be found [here](#).

CALL TO ORDER

Mayor Pruitt called the meeting of the Mill Creek City Council to order at 6:00 p.m. and led the Pledge of Allegiance.

PLEDGE OF ALLEGIANCE

ROLL CALL

Councilmembers Present:

*Pam Pruitt, Mayor
Brian Holtzclaw, Mayor Pro Tem
Vince Cavaleri, Councilmember
Mike Todd, Councilmember
Mark Bond, Councilmember*

Councilmembers Absent:

*Donna Michelson, Councilmember
Sean Kelly, Councilmember*

Councilmember Cavaleri made a motion to excuse Councilmember Michelson and Councilmember Kelly due to illness. Councilmember Bond seconded the motion. The motion passed unanimously.

AUDIENCE COMMUNICATION

- A.** Wil Nelson, a Mill Creek resident, commented on the visibility of the City's motorcycle unit over the weekend. Mr. Nelson stated that he does not agree with a property tax increase and would like to see the City re-zone the Dobson Remillard property to single family parcels and sell them.

PRESENTATIONS

- B.** Snohomish Health District Update

Snohomish Health District Administrator Jeff Ketchel led Council through a PowerPoint presentation that highlighted the District's programs, changes, focus, modernization and sustainability. Mr. Ketchel distributed flyers to Council showing how the District has been striving to make things simpler, safer and healthier for Mill Creek.

November 7, 2017 REGULAR COUNCIL MEETING MINUTES

Mr. Ketchel introduced Snohomish Health District Officer Dr. Mark Beatty who gave Council an overview of his education and work accomplishments.

C. Veterans Day Events

City Manager Rebecca Polizzotto recognized Director of Communications & Marketing Joni Kirk and Recreation & Tourism Manager Brian Davern for their efforts in continuing to design the City's Veterans Day events to engage the community, promote tourism and expand the event as a regional event.

The City Manager introduced Recreation & Tourism Manager Brian Davern who provided an overview of the upcoming Veterans Day events, including the Veterans Citizen Advisory Committee, Operation Gratitude Donation Drive, Commemorative Ceremony, Parade and Media Outreach efforts.

CONSENT AGENDA

D. City Council Meeting Minutes of October 3, 2017

E. City Council Meeting Minutes of October 10, 2017

Councilmember Cavaleri made a motion to approve the consent agenda. Councilmember Todd seconded the motion. The motion passed unanimously.

REPORTS

F. Mayor/Council

Mayor Pruitt reported that she attended the first meeting of the Transition Board for the consolidated dispatch centers.

Councilmember Todd reported that he attended the AWC Regional Meeting with City Manager Rebecca Polizzotto and encouraged Council to look at their legislative agenda.

Councilmember Todd acknowledged residents for sharing their concerns about the upcoming property tax public hearing.

Councilmember Todd encouraged Council and residents to look at the proposed Snohomish Conservation District tax increase.

G. City Manager

City Manager Rebecca Polizzotto introduced the City's new Director of Public Works & Development Services, Gina Hortillosa.

City Manager Polizzotto shared that Director of Communications & Marketing Joni Kirk held the first Senior Center Focus Group meeting, will expand the group to Brookdale residents, and has met with the Executive Director of the Northshore Senior Center. City Manager Polizzotto encouraged Council to review the focus group notes that were included in the Council packet.

November 7, 2017 REGULAR COUNCIL MEETING MINUTES

City Manager Polizzotto reported that the Trunk or Treat event was a great success and drew approximately 6000 people to City Hall and noted that there is an event summary in the Council packet.

City Manager Polizzotto reviewed the updated Council Planning Schedule.

City Manager Polizzotto stated that a briefing on the proposed CPP was available for review in the Council packet. Council engaged in a brief discussion and Mayor Pro Tem Holtzclaw suggested that Council explore the topic in early December.

City Manager Polizzotto recognized the Boy Scouts in attendance and invited them to stay and ask questions after the meeting.

AUDIENCE COMMUNICATION

H. There were no comments from the audience.

ADJOURNMENT

With no objection, Mayor Pruitt adjourned the meeting at 7:00 p.m.

Pam Pruitt, Mayor

Peggy Lauerman, City Clerk



MINUTES

City Council Regular Meeting

6:00 PM - Tuesday, November 14, 2017

Council Chambers, 15728 Main Street, Mill Creek, WA 98012

Minutes are the official record of Mill Creek City Council meetings. Minutes document action taken at the council meeting, not what was said at the council meeting.

A recording of this City Council meeting can be found [here](#).

The agenda packet for this City Council meeting can be found [here](#).

CALL TO ORDER

Mayor Pruitt called the meeting of the Mill Creek City Council to order at 6:00 p.m. and led the Pledge of Allegiance.

PLEDGE OF ALLEGIANCE

ROLL CALL

Councilmembers Present:

Pam Pruitt, Mayor
Brian Holtzclaw, Mayor Pro Tem
Sean Kelly, Councilmember
Donna Michelson, Councilmember
Vince Cavaleri, Councilmember
Mike Todd, Councilmember
Mark Bond, Councilmember

Councilmembers Absent:

AUDIENCE COMMUNICATION

- A.** Terry Schuler, Mill Creek Senior Center Program Manager, addressed the Council with concerns about the new senior center site at Vintage Housing.

PRESENTATIONS

- B.** Proclamation: Parks & Recreation Board Member Mark Johnson

Mayor Pruitt read a proclamation recognizing Parks & Recreation Board member Mark Johnson for his service on the Board and wished him well in his future endeavors. Recreation & Tourism Manager Brian Davern presented Mr. Johnson with a token of appreciation from the City.

- C.** Presentation of Check to Colton's Army Guild

City Manager Rebecca Polizzotto introduced Recreation & Tourism Manager Brian Davern and Recreation Coordinator Kristen Rasmussen who briefed Council on the Run with Heart event that benefited two local non-profit organizations. Mr. Davern and Ms. Rasmussen presented a \$4,000 check to Colton's Army Guild. Jeff, Suzy and

November 14, 2017 REGULAR COUNCIL MEETING MINUTES

Colton Matter were on hand to accept the check.

PUBLIC HEARING

D. Property & EMS Tax Levy Public Hearing

City Manager Rebecca Polizzotto reviewed tax levy background information. The City Manager recommended a 1% tax levy increase for both regular and EMS property taxes.

Public Comments:

Wil Nelson, a Mill Creek resident, stated that he did not appreciate another property tax increase, but is okay with a smaller EMS tax increase.

Mayor Pro Tem Holtzclaw made a motion to approve Ordinance #2017-822, AN ORDINANCE OF THE CITY OF MILL CREEK, WASHINGTON, LEVYING REGULAR PROPERTY TAXES UPON ALL PROPERTY; REAL, PERSONAL AND UTILITY SUBJECT TO TAXATION WITHIN THE CORPORATE LIMITS OF THE CITY OF MILL CREEK, FOR THE FISCAL YEAR COMMENCING JANUARY 1, 2018. Councilmember Bond seconded the motion. The motion passed unanimously.

Councilmember Todd made a motion to approve Ordinance #2017-823, AN ORDINANCE OF THE CITY OF MILL CREEK, WASHINGTON, LEVYING EMERGENCY MEDICAL SERVICES PROPERTY TAXES UPON ALL PROPERTY; REAL, PERSONAL AND UTILITY SUBJECT TO TAXATION WITHIN THE CORPORATE LIMITS OF THE CITY OF MILL CREEK, FOR THE FISCAL YEAR COMMENCING JANUARY 1, 2018. Councilmember Michelson seconded the motion. The motion passed unanimously.

NEW BUSINESS

E. Website Update

City Manager Rebecca Polizzotto stated that the City's web design team has been working diligently on the new website that will be going live in approximately 4 weeks and that the new website will include a tourism sub-site, for which the City secured a grant.

City Manager Rebecca Polizzotto introduced Director of Communications & Marketing Joni Kirk who gave Council a preview of the new website. She talked about the web focus group, the new citizen response module, mobile functionality, and briefed Council on a comprehensive communication plan to roll the website out to the community.

CONSENT AGENDA

- F. Approval of Checks #57648 through #57777 and ACH Wire Transfers in the Amount of \$416,977.83
(Audit Committee: Mayor Pruitt and Mayor Pro Tem Holtzclaw)**
- G. Approval of Payroll and Benefit ACH Payments in the Amount of \$648,381.48
(Audit Committee: Mayor Pruitt and Mayor Pro Tem Holtzclaw)**

November 14, 2017 REGULAR COUNCIL MEETING MINUTES

Mayor Pro Tem Holtzclaw made a motion to approve the consent agenda. Councilmember Todd seconded the motion. The motion passed unanimously.

REPORTS

H. Mayor/Council

Mayor Pruitt reported that the newly comprised Snohomish County 911 Board will be meeting three times before the end of the year and will hold a meeting on January 1, 2018 at Fire District 7.

Mayor Pruitt reported that she spent time with students at Penny Creek Elementary talking about local government.

Mayor Pruitt reported that she enjoyed the City's Veterans Day parade.

Councilmember Cavaleri thanked newly elected official, Jared Mead, and candidate Carmen Fischer for participating in the election cycle.

Councilmember Michelson reported that she attended the Art & Beautification Board meeting last week and stated the Board is brainstorming new ideas for tourism. Councilmember Michelson stated they are still looking for artists to help with the utility box wrap project.

Mayor Pro Tem Holtzclaw thanked City staff for social media communications and for providing coverage during last night's storm.

Councilmember Todd reported that the parade was amazing and commented on how far it has come from the first year.

Councilmember Todd encouraged Council to attend the legislative send-off breakfast on January 3.

Councilmember Todd encouraged Council to join him at the Capitol on January 19 to speak with representatives about projects that are important to our City.

I. City Manager

City Manager Polizzotto reviewed the Council Planning Schedule.

City Manager Polizzotto reported that Council goal setting sessions will be the first steps toward the new budget process that begins in January.

City Manager Polizzotto reported that the City was awarded a \$50,000 grant for stormwater efforts and that the funds will be utilized to review years of stormwater system video to identify projects and priorities as part of our capital improvement planning. City Manager Polizzotto recognized Supervising Engineer Kamal Mahmoud for securing the grant.

November 14, 2017 REGULAR COUNCIL MEETING MINUTES

City Manager Polizzotto thanked staff for a great Veterans Day that underscores the City's goal to develop these events as regional events.

City Manager Polizzotto thanked Council for their leadership and for their confidence in City staff.

AUDIENCE COMMUNICATION

- J.** Herbie Martin, a Mill Creek resident, thanked the City Manager for her role in the Veterans Day events. Mr. Martin stated that he would like to see more diversity within the City and embrace all that live in the community.

ADJOURNMENT

With no objection, Mayor Pruitt adjourned the meeting at 7:41 p.m.

Pam Pruitt, Mayor

Peggy Lauerman, City Clerk



Flooding on 136th Overview

Nov. 15, 2017

Incident

A Mill Creek neighborhood was inundated with water on Nov. 15, 2017, when two trees snapped in a Mill Creek wetland, on private property, fell on a beaver dam and smashed it, releasing a gush of water into Mill Creek neighborhoods shortly before 10 a.m.

This was an unfortunate act of nature that occurred on private property and triggered an event that flooded City streets and required the City's involvement. Because this was an act of nature, there is no one "at fault." This was not the result of any action taken by the City. This is just something that occurred.

The subsequent flooding from the private Sullivan wetland closed 136th Street SE in between SR 527 and Jackson High School in Mill Creek. Water flowed into about half a dozen homes, including some in the neighborhood of 14th Court, which ends in a cul-de-sac on 137th Street SE known as the Dumas Lane neighborhood. Residents whose homes or property are damaged were asked to call the City's Public Works department at 425-551-7254 to report issues.



Notifications were distributed to the media, put on the City's website, and shared broadly across social media. Media helicopters were quickly dispatched to the flood location, and camera crews arrived by vehicle within the hour. Media relations personnel were onsite for the duration of the incident. Snohomish County Fire 7's PIO assisted in on-scene media response.



Early on, Everett Public Schools were notified to share information with Jackson High School parents and students and to determine if there were impacts to bus schedules (it was determined there were no impacts to bus routes).

Police and Fire continued to monitor surrounding neighborhoods. It was determined that some homes in the Burk Place neighborhood on 138th and 139th Streets SE and in the Mill Creek Village Condominiums on 13th Place SE experienced some impact.

Crews were called in from Silver Lake Water District and Snohomish County Public Works to help Mill Creek Public Works crews. Silver Lake Water District brought in two pumps, and Snohomish County brought in five pumps. The water was pumped into a type 2 catch basin, which connected to a 24-inch stormwater system. Working with Snohomish Fire District 7, crews were able to divert water from continuing to run into the Dumas Lane neighborhood. However, the water continued to run down 136th Street SE. Crews had to pump water onto SR 527, which closed one lane of northbound traffic shortly after 2 p.m. Snohomish Fire District 7 and Washington State Department of Transportation helped with traffic control in the area.



For nearly six hours, it was unclear as to what had caused the flood. Staff from Snohomish County's Public Works and Surface Water programs, as well as staff from Silver Lake Water District, joined City staff to investigate the situation. Shortly before 4 p.m., the cause of the flood was determined. An announcement was distributed to the media.



Around 5:30 p.m., crews were able to stop the flow of water from the wetlands with environmentally friendly sandbags. Within 45 minutes, the water had completely dissipated as the stormwater system absorbed the water. Crews cleaned the streets and reopened the

roadways about 7:30 p.m. A wrap-up announcement was distributed to media and shared broadly through the City's communications resources.



Media coverage during the event included:

- [Associated Press](#) (with widespread coverage across the U.S.)
- [Everett Herald](#)
- [KING-5 TV](#)
- [KIRO-TV](#)
- [KOMO-TV](#)
- KOMO News Radio
- [Mill Creek Beacon](#)
- [Mill Creek View](#)
- [News of Mill Creek](#)
- [Q13-TV](#)

Post-Event

The City's Public Works crew checked all locations at approximately 6:45 a.m. on Thursday, Nov. 16. All sandbags were intact and the water flow was well controlled. Crews are continuing to check the locations and clear any accumulation of debris from the inlet to the City's storm water system next to the 13325 property.

Media calls continued to come the day following the event for follow-up stories. Information they requested is as follows, along with the City's response:

- Name of the property owner on which the wetlands are situated? (*This was provided*)
- How did two trees fall at the same time? (*City response: It was an act of nature; we weren't there to see how it occurred, we just know it occurred*)
- Who is going to pay for the damages? (*City response: Since this is an unfortunate act of nature, no one is "at fault." We encourage people to contact their insurance provider to determine coverage. If they feel that they want to submit a claim, they may do so directly with the City's insurance provider, WCIA, and the insurance adjuster will make a determination.*)
- Beaver dam mitigation efforts in the past? (*City response: Unknown. This is private property.*)
- Is this a result of the Arena Sports development? (*City response: The Arena Sports facility is downhill and downstream from this wetland. Further, it is on a different drainage system, so it is unrelated to this incident.*)

The City contacted the State's Emergency Management Division, which operates FEMA *Public Assistance*, to determine aid options for homeowners. FEMA's Individual Assistance program is applicable when homes are left in "unlivable" conditions. This was clearly not the case for the homes in these neighborhoods, as homeowners were staying inside the homes the evening of the flood. The other options consisted of low incomes loans and VOADs (voluntary organizations active in disaster, such as American Red Cross or religious organizations); both of these options would require 25 homes or more to be underinsured. That is not the case in Mill Creek, where it is estimated that only a half dozen homes were impacted.

City staff also spoke with Maryann Richards, the assigned insurance adjuster for WCIA, the City's insurance carrier. Maryann actually visited the scene the afternoon of the flood. She directed the City to refer any impacted residents to contact their insurance carrier as well as to call her directly. This information was provided to the Public Works front office personnel and the senior leadership team. An email was sent to all staff notifying them that all queries, via the phone, in writing or in person, should be directed to the Public Works front office to ensure messaging is consistent. Media queries continue to be handled by Communications and Marketing.

The agencies that assisted with the effort have notified the City that, given the magnitude of the work, the City should expect some billing. This includes rough estimates of \$15-20K from Snohomish County, and \$5K each from WSDOT and Silver Lake Water District. The City's Public Works crew worked overtime, and Snohomish County Fire District 7 also had people on site for extended periods of time. Actual costs will depend on the mutual aid agreements that the City has with each agency (OT, regular time, etc.).

The City also is assessing impacts of the additional stress on the stormwater system. At this time, staff are gathering information on video surveys conducted on our storm water system (pipes) within the vicinity of the flood. There was a survey conducted in 2015 in areas south of the flood. We are still doing more investigative work to learn more about the conditions of the system and include any necessary projects in the Capital Improvement Plan or address with maintenance if feasible.

Follow-up coverage on November 16 came from the following outlets, though no additional media calls have been received since Nov. 16:

- [KIRO-TV](#), wondering if the City was going to be able to help people.
- [KOMO-TV](#), which asked the question if anyone was liable.

Prior History

Last winter, there was some flooding in the yard of the home directly across the street from the High School on 136th. Flooding was suspected from beaver activity within the swamp drainage. Flooding was localized to within the wetland/buffer and the house yard.

The homeowner has previously secured an emergency hydraulic project approval (HPA) from the Washington Dept. of Fish and Wildlife to hand-remove a section of the dam. This action was initiated by the homeowner and the City was not involved at all, as this is private property.

The City is not aware of any significant flooding previously in Dumas Lane neighborhood.



UPDATE ON PROPOSED AMENDMENTS TO COUNTYWIDE PLANNING POLICIES

A report regarding a proposed amendment to the Countywide Planning Policies (CPPs) was included in the November 7, 2017 Council packet. The amendment, if ultimately approved by the Snohomish County Council, would allow different Urban Growth Areas (UGAs) to modify their UGA boundary for the purpose of swapping population and/or employment capacity. Currently, boundary adjustments can only be done within the same UGA. The text of the proposed CPP amendment is as follows:

CPP - DP-3 “Following consultation with the affected city or cities, the County may adjust urban growth areas – defined in this policy as concurrent actions to expand an Urban Growth Area (UGA) in one location while contracting ~~the same a~~ UGA in another location – without resulting in a net increase of population or employment land capacity. Such action may be permitted when consistent with adopted policies...”

As was stated in the November 7 report, the review process for a CPP amendment includes review and a recommendation by the Snohomish County Tomorrow (SCT) Planning Advisory Committee (PAC). A copy of the November 7 report including potential pros and cons for Mill Creek is attached for reference.

The PAC met last Thursday, November 9. On the agenda was the proposed CPP amendment. At the PAC meeting, most PAC members supported the flexibility provided by the proposed amendment. However, the PAC was of the opinion that affected cities (Cities adjacent to UGAs proposed for expansion or constriction) should have to approve the change to the UGA boundary revision (the original proposed CPP language only requires the County to consult with affected cities). Requiring an affected city to agree to a change to their UGA or adjacent to their UGA is important to cities such as Mill Creek as it provides strong leverage to cities in mitigating any potential impacts that a boundary revision would have and would prevent the County from changing a city’s UGA without their consent.

After discussion on the proposed CPP amendment, the PAC voted to recommend approval of the CPP amendment to the SCT Steering Committee with revisions as shown below:

*CPP - DP-3 “Following consultation **and agreement with** the affected city or cities, the County may adjust urban growth areas – defined in this policy as concurrent actions to expand an Urban Growth Area (UGA) in one location while contracting ~~the same a~~ UGA in another location – without resulting in a net increase of population or employment land capacity. Such action may be permitted when consistent with adopted policies...”*

It should be noted that the vote was not unanimous. Two PAC members did vote against the proposal (representatives from Snohomish County and Woodway). Affirmative votes were cast by representatives from Mill Creek, Lynnwood, Everett, Lake Stevens, the Tulalip Tribe, Marysville, Granite Falls, and Mukilteo.

The proposed matter will be considered by the Steering Committee at their November 29 meeting (one week later than usual as a result of the Thanksgiving Holiday). Mayor Pro Tem Holtzclaw is the City of Mill Creek representative. Final consideration will be by the County Council.

Attachment:

City Council Report "Briefing to Proposed Countywide Planning Policies" (previously distributed in the November 7, 2017 Council meeting packet)



BRIEFING ON PROPOSED COUNTYWIDE PLANNING POLICIES - NOV 7, 2017

Background

As required by the Growth Management Act, Countywide Planning Policies (CPPs) have been adopted by the Snohomish County Council. The policies include rules for expanding Urban Growth Areas and population targets for the County's jurisdictions. The Comprehensive Plans of all jurisdictions in Snohomish County must be consistent with the CPPs.

On September 27, 2017, the Snohomish County Council passed Motion 17-320, which referred a proposed amendment to CPP-DP-3 to Snohomish County Tomorrow (SCT) for consultation, consideration, and a recommendation back to the County Council. The proposed amendment would remove the requirement that capacity-neutral land swaps only occur within *the same* urban growth area (UGA). For example, in the Southwest Urban Growth Area (SWUGA), since they are in the same UGA, Everett could reduce their UGA area in the Lowell Larimer Road area and Mill Creek could expand its UGA to the east if the overall population and population capacity do not change. Also, MUGA areas within the SWUGA can be swapped under the current policy. If the proposed CPP amendment is approved, boundary lines in separate, disconnected UGAs (such as the SWUGA and the Granite Falls UGA) could be adjusted to swap population and employment capacity.

The CPP amendment was originally proposed as part of a separate application to amend the Snohomish County Comprehensive Plan to expand the SWUGA east of Mill Creek. The application is from a property owner outside the SWUGA and LDC, Inc.

Amendments to the CPPs require review by Snohomish County Tomorrow (SCT), with final action taken by the County Council. The SCT review process utilizes the Planning Advisory Committee (PAC), which is a subcommittee of the Steering Committee made up of planning directors/managers from the County jurisdictions. The PAC will discuss the proposal and forward a recommendation, including any recommended changes, to the SCT Steering Committee. The Steering Committee is comprised of City and County elected officials (Mayor Pro Tem Brian Holtzclaw represents Mill Creek). The Steering Committee will review the proposal and make a recommendation to the County Council.

The PAC will be reviewing the proposed CPP amendment at its November 9th meeting. The Steering Committee is scheduled to review and vote on a recommendation to the County Council at their meeting on November 29.

Proposed CPP Amendment

The proposed CPP amendment under consideration is as follows:

CPP - DP-3 "Following consultation with the affected city or cities, the County may adjust urban growth areas – defined in this policy as concurrent actions to expand an Urban Growth Area (UGA) in one location while contracting UGA in another location – without resulting in a net increase of population or employment land capacity. Such action may be permitted when consistent with adopted policies..."

- This proposed change would simply remove the words "the same" and add the word "a."

- The policy currently allow swaps within the Southwest Urban Growth Area (SWUGA) as they are all in the same SWUGA. The amendment has no direct impact on MUGAs.
- Unconnected UGAs (for example, Snohomish and Lake Stevens) do not currently have the flexibility to swap capacity.
- Allowing flexibility to swap capacity between separate UGAs could theoretically benefit cities that are willing to make such swaps and could help jurisdictions address rural/urban boundary issues.

Other Related Considerations – Proposed Snohomish County Comprehensive Plan Amendment

Separate from the proposed CPP amendment is an application from property owners and LDC, Inc. to amend the County's Comprehensive Plan to expand the SWUGA. The proposed SWUGA expansion area is just east of the Mill Creek and Bothell MUGAs, near 43rd Avenue SE. (See attachedment). The amendment would potentially swap population capacity from another UGA, such as the Granite Falls UGA, to the SWUGA. Thus, approval of the CPP amendment to allow swaps between UGAs might be necessary for a Comprehensive Plan Amendment to be approved.

The request to expand the SWUGA east of the Mill Creek and Bothell MUGAs makes the case that the expansion would address an existing rural/urban land conflict near 43rd Avenue SE. Snohomish County Public Works is now planning a road improvement project to connect 43rd Avenue from Sunset Road on the North to Malty Road on the South. The intent is to make 43rd Avenue a primary alternative for traffic on 35th Avenue. The proposed UGA expansion would result in both sides of 43rd Avenue being designated Urban.

Potential Impact of the Proposed CPP to City of Mill Creek

Approval of the CPP would have no direct impact on the City of Mill Creek. The policy change would apply countywide and does not expand the SWUGA, or result in additional development impacts in the Mill Creek vicinity.

That being said, approval of the CPP could have an indirect impact on Mill Creek as it could ultimately result in an expansion of the SWUGA just east of Mill Creek. Staff has not reviewed the proposal in detail; but, presumably, if an expanded SWUGA is approved, additional development would occur east of Mill Creek. Additional traffic would utilize the City's road system and residents would utilize the City's park system. If the City of Mill Creek is opposed to any UGA expansion in the vicinity of Mill Creek, one strategy may be to oppose the change to the CPP which would block any UGA expansion that uses capacity outside the SWUGA.

On the other hand, environmental impacts from an expanded SWUGA may be small relative to the whole picture. Increased development near Mill Creek could even provide benefits in the form of increased sales tax from the new residents shopping in Mill Creek and traffic impact mitigation fees paid directly by the developer. It should be noted that there is also potential for a voluntary mitigation agreement with the proponents of the UGA expansion. For example, in 2005, the City negotiated a voluntary agreement with Cam West during Snohomish County's consideration of their proposed UGA expansion south of 180th Street and east of 35th Avenue. The agreement resulted in approximately \$1 million of park mitigation fees being paid to the City to offset impacts to the City's park system.

The proposed CPP amendment was discussed at the October PAC meeting. Some city representatives seemed to be in favor of adding additional flexibility to allow population and employment capacity swaps between UGAs. It should be noted that any proposed UGA changes have to meet many other criteria and are subject to extensive public participation requirement. Approval of the proposed CPP amendment does not approve or endorse any change to an UGA.

ATTACHMENTS:

- Map of current UGA Boundaries
- Selected Countywide Planning Policies addressing UGA Boundaries
- Map of proposed SWUGA expansion

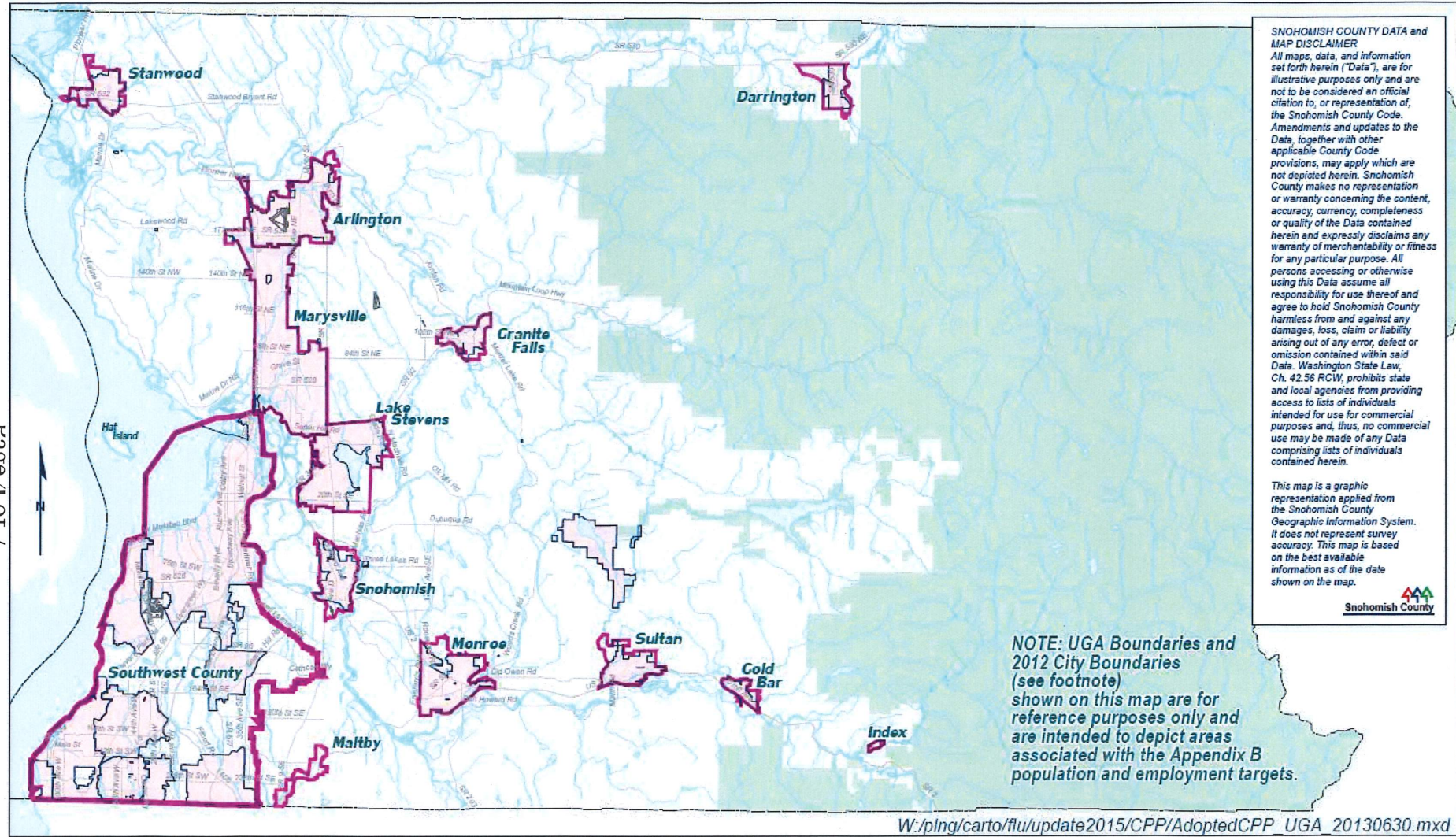

Attachment 1

DRAFT

Attachment 2

DRAFT

Countywide Planning Policies

- DP-1** The County shall maintain Urban Growth Areas (UGAs), as shown on the map in Appendix A, that:
- a. When aggregated at the time of 10-year updates, shall include additional capacity to accommodate at least 100%, but no more than 115%, of the County's adopted 20-year urban allocated population growth projection;
 - b. Include all cities in Snohomish County;
 - c. Can be supported by an urban level of service consistent with capital facilities plans for public facilities and utilities;
 - d. Are based on the best available data and plans regarding future urban growth including new development, redevelopment, and infill;
 - e. Have identifiable physical boundaries such as natural features, roads, or special purpose district boundaries when feasible;
 - f. Do not include designated agricultural or forest land unless the city or County has enacted a program authorizing transfer or purchase of development rights;
 - g. Have been evaluated for the presence of critical areas;
 - h. Where possible, include designated greenbelts or open space within their boundaries and on the periphery of the UGA to provide separation from adjacent urban areas, rural areas, and resource lands;
 - i. Should consider the vision of each jurisdiction regarding the future of their community during the next 20 years;
 - j. Are large enough to ensure an adequate supply of land for an appropriate range of urban land uses to accommodate the planned growth; and
 - k. Support pedestrian, bicycle and transit compatible design.
- DP-2** An expansion of the boundary of an individual Urban Growth Area (UGA) that results in a net increase of residential, commercial or industrial land capacity shall not be permitted unless:
- a. The expansion is supported by a land capacity analysis adopted by the County Council pursuant to RCW 36.70A.110;
 - b. The expansion otherwise complies with the Growth Management Act;
 - c. Any UGA expansion should have the support of affected cities. Prior to issuing a decision on a UGA boundary change, the County shall consult with affected cities and give substantial weight to a city's position on the matter. If the County Council approves an expansion or contraction of a UGA boundary that is not supported by an affected city, it shall include in its findings how the public interest is served by the UGA expansion or contraction despite the objection of an affected city; and
 - d. One of the following conditions is met:
 - 1. The expansion is a result of the most recent buildable lands review and evaluation required by RCW 36.70A.215 and performed per policy GF-7 following the procedures in Appendix E.
 - 2. The expansion is a result of the review of UGAs at least every ten years to accommodate the succeeding twenty years of projected growth, as projected by the State Office of Financial Management, and adopted by the County as the 20-year urban allocated population projection as required by RCW 36.70A.130(3).
 - 3. Both of the following conditions are met for expansion of the boundary of an individual UGA to include additional residential land:
 - (a) Population growth in the UGA (city plus unincorporated UGA) since the start of the twenty-year planning period, equals or exceeds fifty percent of the additional population capacity estimated for the UGA at the start of the planning period. Acceptable sources of documentation are the most recent Snohomish County

DRAFT

- Tomorrow (SCT) Growth Monitoring Report (GMR) or the buildable lands review and evaluation (Buildable Lands Report [BLR]), and
- (b) An updated residential land capacity analysis conducted by city and County staff for the UGA confirms the accuracy of the above finding using more recent residential capacity estimates and assumptions, and any new information presented at public hearings that confirms or revises the conclusions is considered.
4. Both of the following conditions are met for expansion of the boundary of an individual UGA to include additional employment land:
 - (a) Employment growth in the UGA (city plus unincorporated UGA) since the start of the twenty-year planning period, equals or exceeds fifty percent of the additional employment capacity in the UGA at the start of the planning period. Acceptable sources of documentation are the most recent SCT GMR or the buildable lands review and evaluation (BLR), and
 - (b) An updated employment land capacity analysis conducted by city and County staff for the UGA confirms the accuracy of the above finding using more recent employment capacity estimates and assumptions.
 5. The expansion will correct a demonstrated mapping error.¹⁰
 6. Schools (including public, private and parochial), churches, institutions and other community facilities that primarily serve urban populations within the urban growth area in locations where they will promote the local desired growth plans should be located in an urban growth area. In the event that it is demonstrated that no site within the UGA can reasonably or logically accommodate the proposed facilities, urban growth area expansions may take place to allow the development of these facilities provided that the expansion area is adjacent to an existing UGA.
 7. In UGAs where the threshold in Condition 4 has not been reached, the boundary of an individual UGA may be expanded to include additional industrial land if the expansion is based on the criteria contained in RCW 36.70A.365 for the establishment of a major industrial development. This assessment shall be based on a collaborative County and city analysis of large developable industrial site needs in relation to land supply. "Large developable industrial sites" may include land considered vacant, redevelopable, and/or partially-used by the Buildable Lands Program (per GF-7 and Appendix E of these CPPs) and may include one or more large parcels or several small parcels where consolidation is feasible.
 8. The expansion will result in the realization of a significant public benefit as evidenced by Transfer of Development Rights (TDR) to the expansion area from Agriculture or Forest lands designated as TDR sending areas. The expansion area shall not be a designated forest or agricultural land of long-term significance.
 9. The expansion will permanently preserve a substantial land area containing one or more significant natural or cultural feature(s) as open space adjacent to the revised UGA boundary and will provide separation between urban and rural areas. The presence of significant natural or cultural features shall be determined by the respective legislative bodies of the county and the city or cities immediately adjacent to the proposed expansion, and may include, but are not limited to, landforms, rivers, bodies of water, historic properties, archeological resources, unique wildlife habitat, and fish and wildlife conservation areas.
 10. The expansion is a response to a declaration by the County Executive, or the County Council by resolution, of a critical shortage of affordable housing which is incurable in a timely manner by the implementation of reasonable measures or other instrumentality reasonably available to the jurisdiction, and the expansion is reasonably calculated to provide affordable housing.
 11. The expansion will result in the economic development of lands that no longer satisfy the designation criteria for natural resource lands and the lands have been redesignated to an appropriate non-resource land use designation. Provided that expansions are supported by

DRAFT

the majority of the affected cities and towns whose UGA or designated MUGA is being expanded and shall not create a significant increase in total employment capacity (as represented by permanent jobs) of an individual UGA, as reported in the most recent Snohomish County Tomorrow Growth Monitoring Report in the year of expansion.

- DP-3** Following consultation with the affected city or cities, the County may adjust urban growth areas – defined in this policy as concurrent actions to expand an Urban Growth Area (UGA) in one location while contracting the same UGA in another location – without resulting in a net increase of population or employment land capacity. Such action may be permitted when consistent with adopted policies and the following conditions:
- a. The area being removed from the UGA is not already characterized by urban development, and without active permits that would change it to being urban in character; and
 - b. The land use designation(s) assigned in the area removed from the UGA shall be among the existing rural or resource designations in the comprehensive plan for Snohomish County.
- DP-4** The County and cities shall use consistent land capacity analysis methods as approved by the Snohomish County Tomorrow Steering Committee.

Attachment 3

20170308 UGA_Feasibility_Map.mxd | MOD: 03/08/2017 | JRG

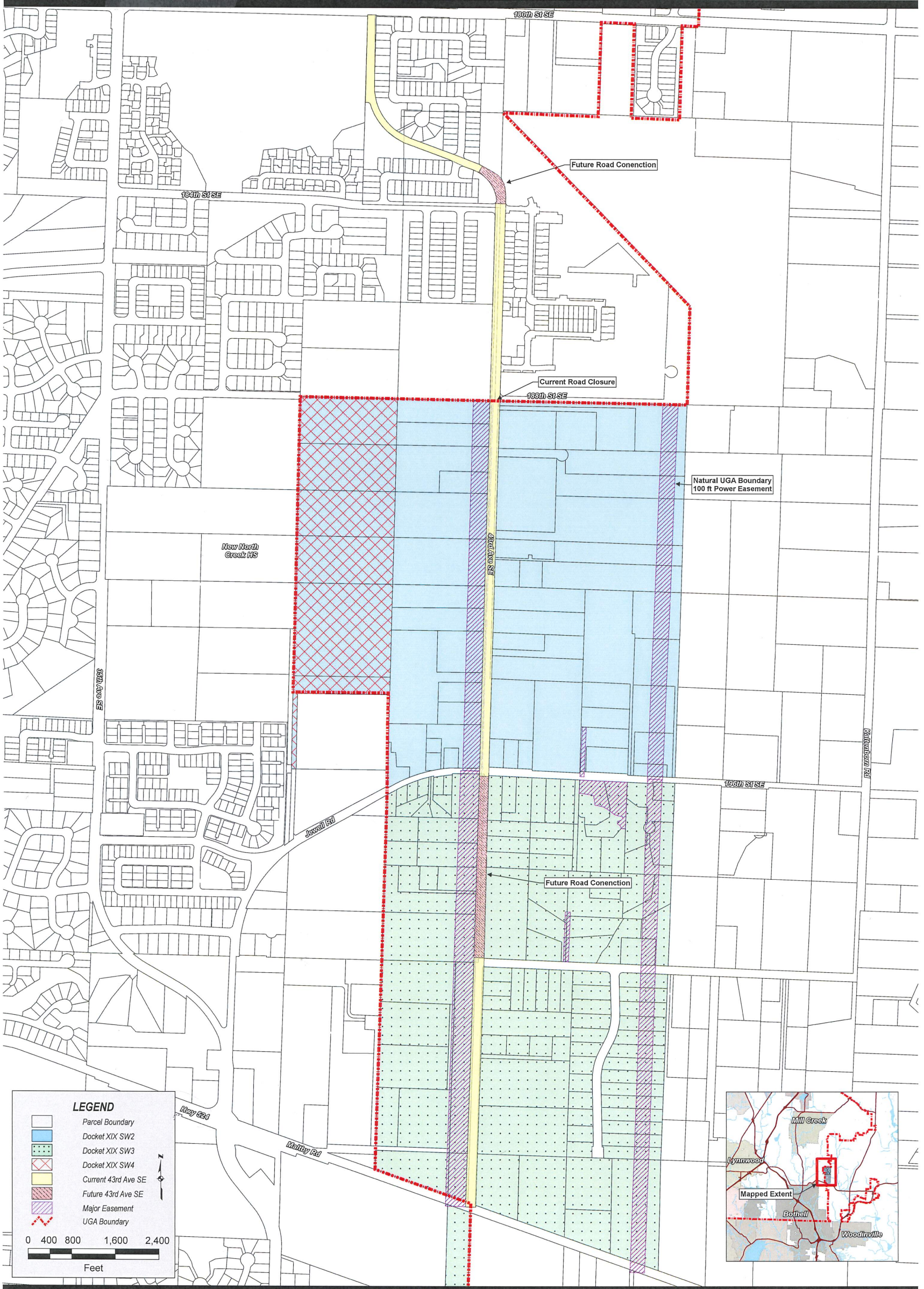

LEGEND

- Parcel Boundary
- Docket XIX SW2
- Docket XIX SW3
- Docket XIX SW4
- Current 43rd Ave SE
- Future 43rd Ave SE
- Major Easement
- UGA Boundary

0 400 800 1,600 2,400
Feet

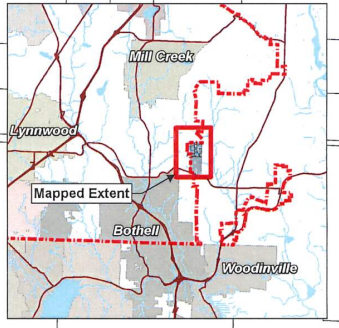

FIGURE:
1.0

PROJECTION: WASHINGTON
STATE PLANE, NORTH ZONE,
NAD 83 FEET
REVISION:
JOB NUMBER: 16-174
DRAWING NAME: 16-174E001
DESIGNER: J.G.FAULDS
DRAWING BY: J.G.FAULDS
DATE: 03-08-17
SCALE: AS SHOWN
JURISDICTION: SNOHOMISH CO

SOUTHWEST URBAN GROWTH AREA
UGA EXPANSION
FEASIBILITY MAP

LDC
THE CIVIL ENGINEERING GROUP
14201 NE 200th St, #100
Woodville, WA 98072
Ph. 426.806.1869
Fx. 426.482.2893
www.LDCcorp.com

Commercial
Infrastructure
Residential

SOURCE INFORMATION	
SOURCE AGENCY	DESCRIPTION
AERIALS EXPRESS	2012 AERIAL IMAGERY
SNOHOMISH COUNTY RECORDS	EASEMENT LOCATIONS
SNOHOMISH COUNTY GIS	PARCEL BOUNDARY, ROADS, UGA BOUNDARY

DECEMBER						
Sun	Mon	Tue	Wed	Thu	Fri	Sat
					1	2
3	4	5 Council	6	7	8	9
10	11	12 Council	13	14	15	16
17	18	19	20	21	22	23
24	25 ³¹	26 Cancelled	27	28	29	30

JANUARY						
Sun	Mon	Tue	Wed	Thu	Fri	Sat
	1	2 Council	3	4	5	6
7	8	9 Council	10	11	12	13
14	15	16	17	18	19	20
21	22	23 Council	24	25	26	27
28	29 ³¹	30	31			

FEBRUARY						
Sun	Mon	Tue	Wed	Thu	Fri	Sat
				1	2	3
4	5	6 Council	7	8	9	10
11	12	13 Council	14	15	16	17
18	19	20	21	22	23	24
25	26	27 Council	28			

Tentative Council Meeting Agendas
Subject to change without notice

Last updated: November 21, 2017

December 5, 2017

(Agenda Summary due November 21)

- CPSM Presentation
- Naming of new City park
- Update MCMC 12.12.165 – Smoking in parks
- Reports:
 - 35th Ave Project Update

December 12, 2017

(Agenda Summary due November 28)

- SERS Presentation
- SNOCOM/SNOPAC Consolidation ILA
- Outgoing Council Recognition
- 2017 Budget Adjustments

December 26, 2017 – No Meeting

January 2, 2018

(Agenda Summary due December 19)

- Swearing in Ceremony – Councilmembers
- Mayor/Mayor Pro Tem Election
- Council Committee Assignments
- Presentation: Council-Manager Relations

January 9, 2018

(Agenda Summary due December 27)

- Presentation: Long Term Planning
- PRA Policy/Ordinance

January 23, 2018

(Agenda Summary due January 9)

- Work Session: Long Term Planning
 - Fiscal Responsibility
 - Community Preservation
 - Civic Pride

February 6, 2018

(Agenda Summary due January 23)

- Work Session: Long Term Planning
 - Customer Service
 - Recreational Opportunities
 - Public Safety

Work in Progress – Upcoming Agenda Items

- CIP Work Plan
 - Director Recruitment
 - CIP Financial Policies
 - Budget Calendar
 - Citizen Budget Tool
 - Stormwater Review & Cost Projections
 - Council Work sessions – Long Term Planning
- Fire Contract
- Guild Contract
 - Bargaining Dates Scheduled
- Personnel Policies and Procedures
 - Job Descriptions Finalized
 - Compensation Analysis Complete
 - ADP Performance Evaluation System being built.
- Public Works Shop Design
- Code Revision – Repeal of Board of Appeals/Adjustment

Possible Work Session Topics for Discussion

- Parking Codes
- Business signs
- MCCA storm water discussions
- Sports Fields
- Repair Issues
- Utility Project Management
- Review of Criminal Justice Costs/Alternatives
- Status update on County’s SHR project
- 128th St as an ST3 Station
- Issues re: no parking on sidewalks
- Development Projects in Progress
- Hotel/Motel Theater Tax
- Resort Fees
- Partnerships with Everett School District
- Development code change to allow redevelopment along Mill Creek Blvd/North Creek
- Council Chambers Configuration